

EDGE - 5050

EDGE 5050 is an RFID hard tag optimized for securing metal assets. The tag is made to stand in a harsh environment based on rugged construction, square footprint, and good durability. It is ideal for Logistics & Supply chain, and manufacturing applications.

The tag can be easily mounted on any metal surface mechanically by using screws or pop rivets, cable ties.



Applications



Warehouse Management



Retail Management



Asset Tracking

Product Drawing:

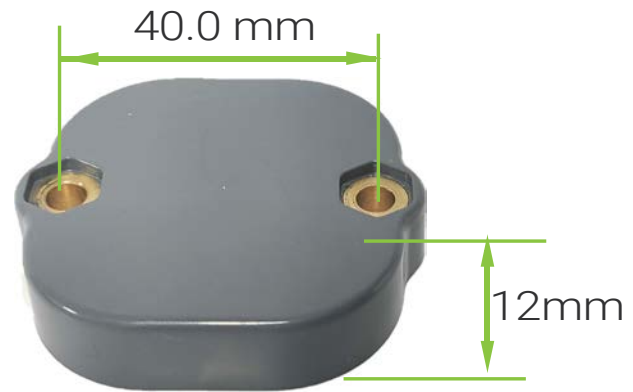

Ordering Information

Part Number	Item Details
RFAB-071008-ETSI/FCC	On-Metal Tag tag with M781 IC
RFAB-070108-ETSI/FCC	On-Metal Tag tag with monza4QT IC

Electrical Specifications

Operational Frequency	FCC: 902-928MHz ETSI: 865- 868 MHz
Interface Protocol	ISO 18000-63 and EPCglobal Gen2v2
Chip Type*	IMPINJ MONZA M4QT
Memory Configuration	EPC Memory – 128 bits User Memory- 512 bits
Data Retention	50 Years
Write Cycle Endurance	100,000 cycles
Read Range**	Upto 10 Meter

Product Characteristics

Tag Size	50 x 50 x 12 mm/1.96 x 1.96 x 0.47 in
Yield	100 %
Material	ABS
Packaging	100 Tags / Packet
Attachment	Screw , Riveting

Environmental Specifications

Operating Temperature	-40 to +85 °C
Storage Temperature	-40 to +85°C
IP Rating	IP68

Personalization

- Customer specific encoding of EPC
- Customised printing of logo, text, barcode etc

READ RANGE GRAPH

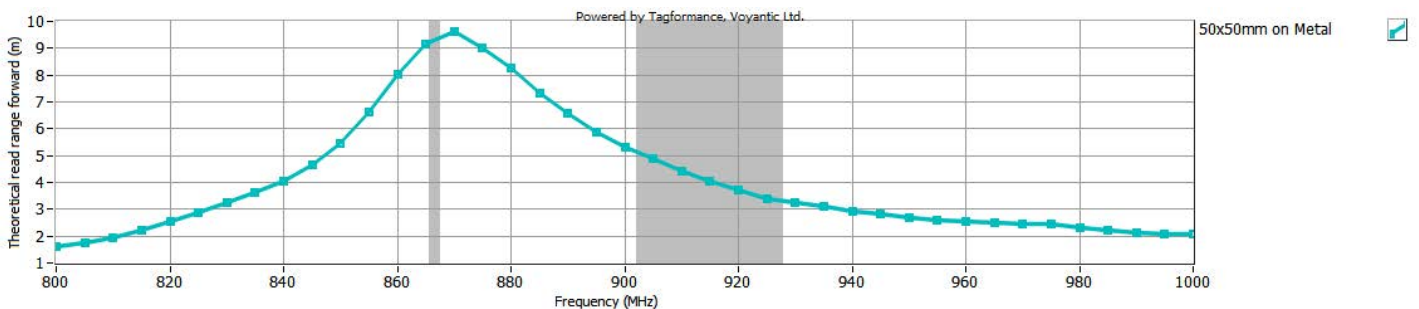

** The indicated read range values are measured in our laboratory testing environment, where antennas with optimum directivity are used with maximum allowed operating power. Different surface materials and environments may exhibit different results.