

# LINEAR ANTENNAS

MT-242020/NV/K  
865 - 870 MHZ, 9.5 DBI LINEAR VERTICAL POLARITY READER ANTENNA



## ELECTRICAL

REGULATORY COMPLIANCE	RoHS, CE 0682
FREQUENCY RANGE	865-870 MHz
GAIN	9.0 dBi (min) 10 dBi (max)
VSWR	1.3:1 (max)
POLARIZATION	Linear Vertical
3dB ELEVATION BEAMWIDTH	58°(typ)
3dB AZIMUTH BEAMWIDTH	60°(typ)
AZIMUTH SIDELobe LEVEL	-23dB @ ±110 to±180
ELEVATION SIDELobe LEVEL	-22dB @ ±110 to±180
F/B RATIO	-21 dB (max)
CROSS POLARIZATION ELEVATION	-25 dB (max)
CROSS POLARIZATION AZIMUTH	-17dB max)
POWER	6W (max)
INPUT IMPEDANCE	50 (ohm)
LIGHTNING PROTECTION	DC Grounded

## MECHANICAL

DIMENSIONS (LxWxD)	305x305x25mm (max)
CONNECTOR	SMA right angle female
WEIGHT	1.2kg (max)
MOUNTING KIT	MT-120018
RADOME MATERIAL	Plastic, UV Resistant
BASE PLATE MATERIAL	Aluminum with chemical conversion coating
OUTLINE DRAWING	RD42492100C

**ENVIRONMENTAL**

<b>TEST</b>	<b>STANDARD</b>	<b>DURATION</b>	<b>TEMPERTURE</b>	<b>NOTES</b>
LOW TEMPERATURE	IEC 68-2-1	72 h	-55°C	
HIGH TEMPERATURE	IEC 68-2-2	72 h	+71°C	
TEMP. CYCLING	IEC 68-2-14	1 h	-45°C +70°C	3 Cycles
THERMAL SHOCK NONO-OPERATING			-30°C to+70°C	Ramp 30°C/min
HUMIDITY	ETSI EN300-2-4 T4.1E	144 h		95%
WATER TIGHTNESS	IEC 529			IP67 (*please see comment below)
DUST RESISTANCE				IP67
SOLAR RADIATION	ASTM G53	1000h		
OZONE RESISTANCE	ETSI 300			
FLAMMABILITY	UL 94			Class HB
QUASI RANDOM VIBRATION				20g rms for 4 hours
VEHICLE VIBRATION OPERATING	1 grms,10-500 Hz, in 3 axis			6 hours total, 2 hr in each axis. Accelerated wear – an additional 50hrs in worst case axis.
MECHANICAL SHOCK OPERATING	10g,11msec, half sine pulse			

\*For outdoor installations that require mounting the antenna horizontally facing ground, please contact MTI representative for the dedicated P/N

**AZIMUTH RADIATION PATTERN MIDBAND  
FREQ. 0.867 GHZ**

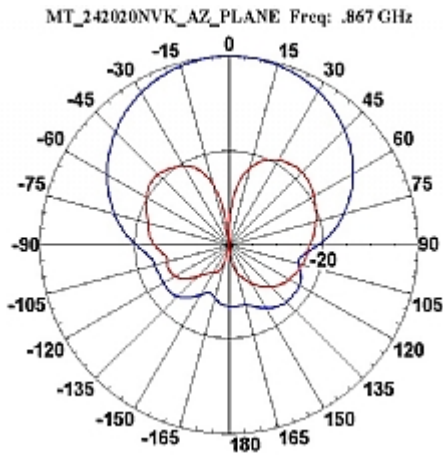

**ELEVATION RADIATION PATTERN MIDBAND  
FREQ. 0.867 GHZ**

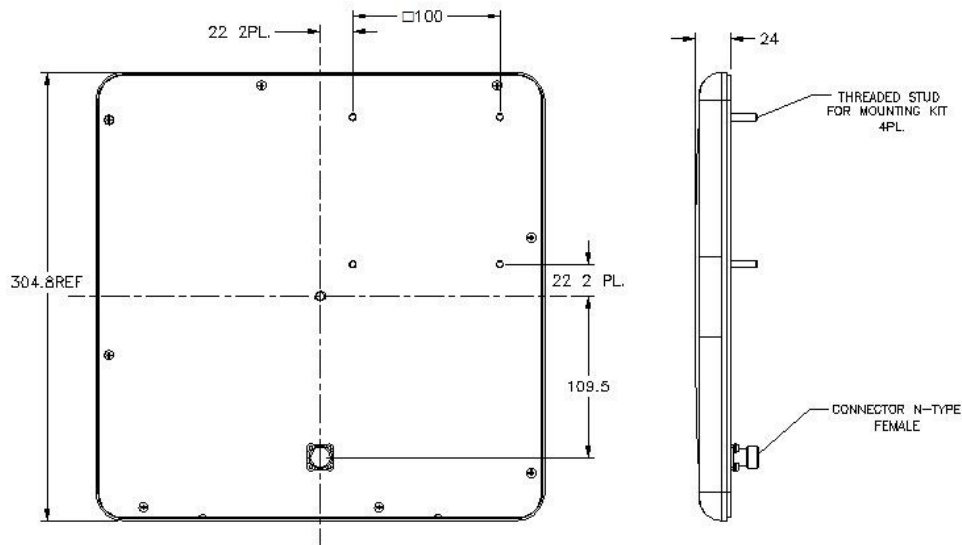
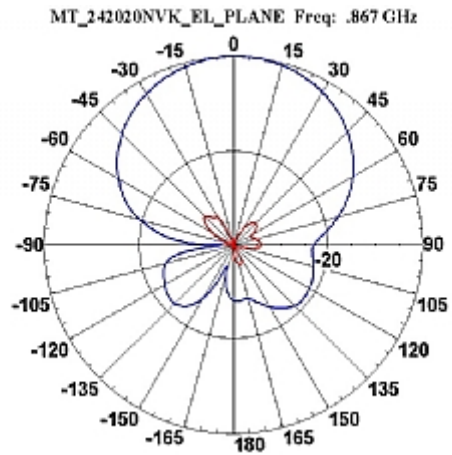

**WAIVER!**

While the information contained in this document has been carefully compiled to the best of our present knowledge, it is not intended as presentation or warranty of any kind on our part regarding the fitness of the products concerned for any particular use or purpose and neither shall any statement contained herein be construed as a recommendation to infringe any industrial property rights or as a license to use any such rights. The fitness of each product for any particular purpose must be checked beforehand with our specialists.