



Newland AIDC
Scanning Made Simple



Fixed Mount Smart Scanner

NLS-FM600

**User
Guide**

Disclaimer

Fujian Newland Auto-ID Tech. Co., Ltd. All rights reserved.

Please read through the manual carefully before using the product and operate it according to the manual. It is advised that you should keep this manual for future reference.

Do not disassemble the device or remove the seal label from the device, doing so will void the product warranty provided by Fujian Newland Auto-ID Tech. Co., Ltd.

All pictures in this manual are for reference only and actual product may differ. Regarding to the product modification and update, Fujian Newland Auto-ID Tech. Co., Ltd. reserves the right to make changes to any software or hardware to improve reliability, function, or design at any time without notice. The information contained herein is subject to change without prior notice.

The products depicted in this manual may include software copyrighted by Fujian Newland Auto-ID Tech. Co., Ltd or third party. The user, corporation or individual, shall not duplicate, in whole or in part, distribute, modify, decompile, disassemble, decode, reverse engineer, rent, transfer or sublicense such software without prior written consent from the copyright holders.

This manual is copyrighted. No part of this publication may be reproduced, distributed or used in any form without written permission from Newland.

Fujian Newland Auto-ID Tech. Co., Ltd. reserves the right to make final interpretation of the statement above.

Fujian Newland Auto-ID Tech. Co., Ltd.

3F, Building A, No.1, Rujiang West Rd., Mawei, Fuzhou, Fujian, China 350015

<http://www.newlandaidc.com>

Revision History

| Version | Description | Date |
|---------|------------------|----------------------------|
| V1.0.0 | Initial release. | Mar 7 th , 2025 |

Table of Contents

| | |
|--|-----------|
| Preface | 1 |
| Introduction..... | 1 |
| Chapter Description | 1 |
| Explanation of Symbols..... | 2 |
| Explanation of Icons..... | 2 |
| Chapter 1 Getting Started | 3 |
| Introduction..... | 3 |
| Symbologies | 3 |
| Features | 4 |
| Components | 5 |
| Chapter 2 Installation | 6 |
| Introduction..... | 6 |
| Dimensions (unit: mm) | 6 |
| Mounting..... | 7 |
| Button Functions | 9 |
| Lens Cover | 13 |
| Focus Adjust..... | 17 |
| External Interface..... | 20 |
| Bracket..... | 21 |
| ESD..... | 22 |
| Precaution | 22 |
| Thermal Considerations | 23 |
| Ambient Environment..... | 23 |
| Chapter 3 Optics | 24 |
| Introduction..... | 24 |
| Sensor | 24 |
| Illumination | 24 |
| Aimer..... | 24 |
| LED Indicators | 25 |
| Window Size..... | 26 |
| Ambient Light..... | 27 |
| Eye Safety | 27 |
| Depth of Field | 28 |
| Chapter 4 Electrical Specifications | 30 |
| Power Supply..... | 30 |
| Operating Requirements | 30 |

| | |
|---|-----------|
| 12-pin Dupont Interface | 31 |
| DC Interface | 32 |
| USB Interface | 32 |
| RJ45 Interface | 33 |
| DC Characteristics | 34 |
| Operating Voltage | 34 |
| Operating Current | 34 |
| I/O Voltage..... | 35 |
| Chapter 5 External Reference Circuit..... | 36 |
| External Circuit Design..... | 36 |
| Switch Output Circuit..... | 36 |
| Control Input Circuit..... | 37 |
| Chapter 6 Auxiliary Tools | 38 |
| Introduction..... | 38 |
| NSet..... | 38 |
| UFCOM..... | 39 |
| Chapter 7 Configuration | 40 |
| Introduction..... | 40 |
| Barcode Programming..... | 40 |
| Command Programming..... | 40 |
| NSet Programming..... | 40 |
| Programming Barcode/ Programming Command/Function | 41 |
| Use of Programming Barcodes | 42 |
| Default Settings | 43 |
| Factory Defaults..... | 43 |
| Query Product Information..... | 44 |
| Query Product Name..... | 44 |
| Query Firmware Version..... | 44 |
| Query Hardware Version | 45 |
| Query Product Serial Number | 45 |
| Query Manufacturing Date..... | 46 |
| Query OEM Serial Number | 46 |
| Chapter 8 Communication Interface..... | 47 |
| Introduction..... | 47 |
| Adaptive Wired Communication..... | 48 |
| RS-232 Interface..... | 49 |
| Baud Rate..... | 50 |
| Parity Check | 51 |

| | |
|--|-----------|
| Data Bit..... | 52 |
| Stop Bit..... | 52 |
| USB HID Keyboard | 53 |
| USB Country Keyboard Types | 54 |
| Beep on Unknown Character | 58 |
| Emulate ALT+Keypad..... | 59 |
| Code Page..... | 60 |
| Unicode Encoding | 62 |
| Emulate Keypad with Leading Zero..... | 62 |
| Function Key Mapping..... | 63 |
| ASCII Function Key Mapping Table..... | 64 |
| ASCII Function Key Mapping Table (Continued) | 65 |
| Inter-Keystroke Delay | 66 |
| Caps Lock..... | 67 |
| Convert Case..... | 68 |
| Emulate Numeric Keypad | 69 |
| Fast Mode..... | 71 |
| Polling Rate | 72 |
| USB CDC | 73 |
| HID POS (POS HID Barcode Scanner)..... | 74 |
| Introduction..... | 74 |
| Access the Scanner with Your Program..... | 74 |
| Acquire Scanned Data..... | 75 |
| Send Command to the Scanner | 75 |
| VID/PID | 76 |
| Ethernet..... | 77 |
| Device IP configuration..... | 78 |
| Device Group..... | 79 |
| Barcode output channel..... | 81 |
| Chapter 9 System Settings | 82 |
| Debug Mode | 82 |
| Scan Mode | 82 |
| Decode Session Timeout..... | 84 |
| Enter the Detection/ Reading State (Sense Mode)..... | 85 |
| Image Stabilization Timeout (Sense Mode) | 86 |
| Trigger Selection (Sense Mode)..... | 87 |
| Image Change Trigger Sensitivity..... | 88 |
| Reread Timeout | 89 |
| Good Read Delay | 91 |
| Security Level | 92 |

| | |
|--|------------|
| Decode Area | 93 |
| Multi-barcode Settings | 94 |
| Minimum & Maximum Total Number of Decoders | 94 |
| Multi-Barcode Reading Preference | 95 |
| Single Graph Filters Data of The Same code | 95 |
| Multi-barcode Position | 96 |
| Multi-barcode Output | 97 |
| Multi-barcode Separator Settings | 98 |
| Image Flipping | 99 |
| Bad Read Message | 101 |
| Set Bad Read Message | 101 |
| Good Read Signal | 102 |
| Polarity of Good Read Signal | 102 |
| Good Read Indicator Duration | 103 |
| Good Read Indicator Delay | 104 |
| Bad Read Signal | 105 |
| Polarity of Bad Read Signal | 105 |
| Bad Read Indicator Duration | 106 |
| Bad Read Indicator Delay | 107 |
| Trigger | 108 |
| Trigger Signal | 108 |
| Types of Triggering | 108 |
| Debounce | 109 |
| Debounce Time | 109 |
| Image Decoding Timeout | 110 |
| Trigger Commands | 111 |
| Modify Start Scanning Command | 111 |
| Modify Stop Scanning Command | 112 |
| Illumination | 113 |
| Illumination Setting | 113 |
| Lighting Selection | 113 |
| Aiming | 117 |
| Good Read LED | 118 |
| Good Read LED Duration | 119 |
| Power On Beep | 120 |
| Good Read Beep | 120 |
| Good Read Beep Volume | 121 |
| Good Read Beep Duration | 122 |
| Good Read Beep Frequency | 123 |
| Chapter 10 Symbolologies | 124 |

| | |
|---|-----|
| Introduction..... | 124 |
| Global Settings | 124 |
| Enable/Disable All Symbologies..... | 124 |
| Enable/Disable 1D Symbologies | 125 |
| Enable/Disable 2D Symbologies | 125 |
| Enable/Disable Postal Symbologies | 126 |
| Inverse Code | 126 |
| Surround GS1 Application Identifiers (AI's) with Parentheses..... | 127 |
| Code 128..... | 128 |
| Restore Factory Defaults | 128 |
| Enable/Disable Code 128 | 128 |
| Set Length Range for Code 128..... | 129 |
| EAN-8..... | 130 |
| Restore Factory Defaults | 130 |
| Enable/Disable EAN-8..... | 130 |
| Transmit Check Character | 131 |
| 2-Digit Add-On Code | 132 |
| 5-Digit Add-On Code | 133 |
| Add-On Code Required | 134 |
| EAN-13..... | 135 |
| Restore Factory Defaults | 135 |
| Enable/Disable EAN-13..... | 135 |
| Transmit Check Character | 136 |
| 2-Digit Add-On Code | 136 |
| 5-Digit Add-On Code | 137 |
| Add-On Code Required | 137 |
| UPC-E..... | 138 |
| Restore Factory Defaults | 138 |
| Enable/Disable UPC-E | 138 |
| Transmit Check Character | 139 |
| 2-Digit Add-On Code | 139 |
| 5-Digit Add-On Code | 140 |
| Add-On Code Required | 140 |
| Transmit Preamble Character | 141 |
| UPC-A..... | 142 |
| Restore Factory Defaults | 142 |
| Enable/Disable UPC-A..... | 142 |
| Transmit Check Character | 142 |
| 2-Digit Add-On Code | 143 |
| 5-Digit Add-On Code | 144 |

| | |
|---|-----|
| Add-On Code Required | 145 |
| Transmit Preamble Character | 145 |
| Coupon..... | 146 |
| UPC-A/EAN-13 with Extended Coupon Code..... | 146 |
| Coupon GS1 Databar Output..... | 147 |
| Interleaved 2 of 5 | 148 |
| Restore Factory Defaults | 148 |
| Enable/Disable Interleaved 2 of 5..... | 148 |
| Set Length Range for Interleaved 2 of 5..... | 149 |
| Check Character Verification..... | 150 |
| ITF-14..... | 151 |
| Restore Factory Defaults | 151 |
| Enable/Disable ITF-14..... | 151 |
| ITF-6 | 152 |
| Restore Factory Defaults | 152 |
| Enable/Disable ITF-6..... | 152 |
| Matrix 2 of 5..... | 153 |
| Restore Factory Defaults | 153 |
| Enable/Disable Matrix 2 of 5..... | 153 |
| Set Length Range for Matrix 2 of 5..... | 154 |
| Check Character Verification..... | 155 |
| Code 39..... | 156 |
| Restore Factory Defaults | 156 |
| Enable/Disable Code 39..... | 156 |
| Set Length Range for Code 39 | 157 |
| Check Character Verification..... | 158 |
| Transmit Start/Stop Character..... | 159 |
| Enable/Disable Code 39 Full ASCII | 159 |
| Enable/Disable Code 32 (Italian Pharma Code)..... | 160 |
| Code 32 Prefix | 160 |
| Transmit Code 32 Start/Stop Character..... | 161 |
| Transmit Code 32 Check Character | 161 |
| Codabar | 162 |
| Restore Factory Defaults | 162 |
| Enable/Disable Codabar..... | 162 |
| Set Length Range for Codabar | 163 |
| Check Character Verification..... | 164 |
| Start/Stop Character..... | 165 |
| Code 93..... | 166 |
| Restore Factory Defaults | 166 |

| | |
|--|-----|
| Enable/Disable Code 93 | 166 |
| Set Length Range for Code 93 | 167 |
| China Post 25 | 168 |
| Restore Factory Defaults | 168 |
| Enable/Disable China Post 25 | 168 |
| Set Length Range for China Post 25 | 169 |
| Check Character Verification..... | 170 |
| GS1-128 (UCC/EAN-128)..... | 171 |
| Restore Factory Defaults | 171 |
| Enable/Disable GS1-128 | 171 |
| Set Length Range for GS1-128..... | 172 |
| GS1 Databar (RSS) | 173 |
| Restore Factory Defaults | 173 |
| Enable/Disable GS1 Databar | 173 |
| Transmit Application Identifier "01" | 173 |
| GS1 Composite (EAN·UCC Composite)..... | 174 |
| Restore Factory Defaults | 174 |
| Enable/Disable GS1 Composite..... | 174 |
| Enable/Disable UPC/EAN Composite | 175 |
| Code 11 | 176 |
| Restore Factory Defaults | 176 |
| Enable/Disable Code 11 | 176 |
| Set Length Range for Code 11..... | 177 |
| Check Character Verification..... | 178 |
| Transmit Check Character | 179 |
| ISBN..... | 180 |
| Restore Factory Defaults | 180 |
| Enable/Disable ISBN..... | 180 |
| Set ISBN Format..... | 181 |
| ISSN..... | 181 |
| Restore Factory Defaults | 181 |
| Enable/Disable ISSN..... | 182 |
| Industrial 25 | 183 |
| Restore Factory Defaults | 183 |
| Enable/Disable Industrial 25 | 183 |
| Set Length Range for Industrial 25..... | 184 |
| Check Character Verification..... | 185 |
| Standard 25..... | 186 |
| Restore Factory Defaults | 186 |
| Enable/Disable Standard 25 | 186 |

| | |
|--|-----|
| Set Length Range for Standard 25..... | 187 |
| Check Character Verification..... | 188 |
| Plessey..... | 189 |
| Restore Factory Defaults | 189 |
| Enable/Disable Plessey | 189 |
| Set Length Range for Plessey | 190 |
| Check Character Verification..... | 191 |
| MSI-Plessey | 192 |
| Restore Factory Defaults | 192 |
| Enable/Disable MSI-Plessey..... | 192 |
| Set Length Range for MSI-Plessey | 193 |
| Check Character Verification..... | 194 |
| Transmit Check Character | 195 |
| AIM 128..... | 196 |
| Restore Factory Defaults | 196 |
| Enable/Disable AIM 128 | 196 |
| Set Length Range for AIM 128..... | 197 |
| ISBT 128 | 198 |
| Restore Factory Defaults | 198 |
| Enable/Disable ISBT 128..... | 198 |
| Code 49..... | 199 |
| Restore Factory Defaults | 199 |
| Enable/Disable Code 49..... | 199 |
| Set Length Range for Code 49 | 200 |
| Code 16K | 201 |
| Restore Factory Defaults | 201 |
| Enable/Disable Code 16K..... | 201 |
| Set Length Range for Code 16K | 202 |
| Pharmacode | 203 |
| Restore Factory Defaults | 203 |
| Enable/Disable Pharmacode..... | 203 |
| Pharmacode One-Track | 204 |
| Enable/Disable Pharmacode One-Track..... | 204 |
| Set Pharmacode One-Track Decoding Direction..... | 204 |
| Set the Number of Pharmacode One-Track..... | 205 |
| Pharmacode One-Track Inverse | 206 |
| Set Pharmacode One-Track Quiet Zone..... | 206 |
| Set Pharmacode One-Track Output Format | 206 |
| Pharmacode Two-Track..... | 207 |
| Enable/Disable Pharmacode Two-Track..... | 207 |

| | |
|---|-----|
| Set Pharmacode Two-Track Decoding Direction | 207 |
| Set the Number of Pharmacode Two-Track | 208 |
| Pharmacode Two-Track Inverse..... | 209 |
| Set Pharmacode Two-Track Quiet Zone..... | 209 |
| Set Pharmacode Two-Track Output Format..... | 209 |
| PDF417 | 210 |
| Restore Factory Defaults | 210 |
| Enable/Disable PDF417 | 210 |
| Set Length Range for PDF417 | 211 |
| PDF417 Inverse | 212 |
| Character Encoding..... | 212 |
| PDF417 ECI Output | 213 |
| Micro PDF417..... | 214 |
| Restore Factory Defaults | 214 |
| Enable/Disable Micro PDF417 | 214 |
| Set Length Range for Micro PDF417..... | 215 |
| QR Code | 216 |
| Restore Factory Defaults | 216 |
| Enable/Disable QR Code..... | 216 |
| Set Length Range for QR Code | 217 |
| QR Inverse | 218 |
| Character Encoding..... | 218 |
| QR ECI Output..... | 219 |
| URL QR..... | 219 |
| Micro QR Code..... | 221 |
| Restore Factory Defaults | 221 |
| Enable/Disable Micro QR | 221 |
| Set Length Range for Micro QR..... | 222 |
| Aztec | 223 |
| Restore Factory Defaults | 223 |
| Enable/Disable Aztec Code | 223 |
| Set Length Range for Aztec Code..... | 224 |
| Aztec Inverse | 225 |
| Character Encoding..... | 226 |
| Aztec ECI Output | 226 |
| Data Matrix..... | 227 |
| Restore Factory Defaults | 227 |
| Enable/Disable Data Matrix | 227 |
| Set Length Range for Data Matrix..... | 228 |
| Rectangular Barcode..... | 229 |

| | |
|--|------------|
| Data Matrix Inverse | 229 |
| Character Encoding..... | 230 |
| Data Matrix ECI Output | 230 |
| Maxicode | 231 |
| Restore Factory Defaults | 231 |
| Enable/Disable Maxicode | 231 |
| Set Length Range for Maxicode..... | 232 |
| Chinese Sensible Code..... | 233 |
| Restore Factory Defaults | 233 |
| Enable/Disable Chinese Sensible Code | 233 |
| Set Length Range for Chinese Sensible Code..... | 234 |
| Chinese Sensible Code Inverse | 235 |
| GM Code | 236 |
| Restore Factory Defaults | 236 |
| Enable/Disable GM | 236 |
| Set Length Range for GM..... | 237 |
| Code One | 238 |
| Restore Factory Defaults | 238 |
| Enable/Disable Code One | 238 |
| Set Length Range for Code One..... | 239 |
| Chapter 11 Prefix & Suffix..... | 240 |
| Introduction..... | 240 |
| Global Settings | 241 |
| Enable/Disable All Prefixes/Suffixes | 241 |
| Prefix Sequence..... | 241 |
| Custom Prefix | 242 |
| Enable/Disable Custom Prefix | 242 |
| Set Custom Prefix | 242 |
| AIM ID Prefix | 243 |
| Code ID Prefix | 244 |
| Restore All Default Code IDs | 244 |
| Modify Code ID | 245 |
| Custom Suffix | 254 |
| Enable/Disable Custom Suffix..... | 254 |
| Set Custom Suffix..... | 254 |
| Terminating Character Suffix..... | 255 |
| Enable/Disable Terminating Character Suffix..... | 255 |
| Set Terminating Character Suffix..... | 255 |
| Chapter 12 Programming Commands | 257 |

| | |
|---|------------|
| Use of Programming Command..... | 257 |
| Command Syntax..... | 257 |
| Query Commands..... | 257 |
| Responses..... | 258 |
| Examples..... | 258 |
| Chapter 13 Batch Programming..... | 260 |
| Introduction..... | 260 |
| Create a Batch Command..... | 261 |
| Create a Batch Barcode..... | 261 |
| Use Batch Barcode..... | 262 |
| Chapter 14 JavaScript Development Guide..... | 263 |
| Introduction..... | 263 |
| Function..... | 263 |
| Core Functions..... | 263 |
| Data Processing Functions..... | 264 |
| Basic Programming Guidelines..... | 264 |
| Variable Management..... | 264 |
| Conditional Judgment..... | 265 |
| Loop Control..... | 265 |
| Advanced String Processing..... | 265 |
| System Configuration Methods..... | 266 |
| Security and Exception Handling..... | 267 |
| Configuration..... | 269 |
| Appendix..... | 270 |
| Digit Barcodes..... | 270 |
| Save/Cancel Barcodes..... | 273 |
| Factory Defaults Table (V1.00.0)..... | 274 |
| AIM ID Table (V1.00.0)..... | 284 |
| Code ID Table (V1.00.0)..... | 286 |
| Symbology ID Number (V1.00.0)..... | 288 |
| ASCII Table..... | 290 |
| Keyboard Key References..... | 294 |
| Calibration Grid..... | 295 |

Preface

Introduction

This manual provides installation, optics, electrical specifications as well as detailed instructions for setting up and using the NLS-FM600 fixed mount barcode scanner (hereinafter referred to as “the FM600” or “the scanner”).

This guide provides programming instructions for the FM600. Users can configure the FM600 by scanning the programming barcodes included in this manual.

The FM600 has been properly configured for most applications and can be put into use without further configuration. Users may check Appendix: Factory Defaults Table for reference.

Chapter Description





- ❖ *Chapter 1, Getting Started* : Gives a general description of the FM600.
- ❖ *Chapter 2, Installation* : Describes how to install the scanner, including installation information, connector, cable, ESD, and environmental considerations.
- ❖ *Chapter 3, Optics* : Provides parameters for optics and illumination.
- ❖ *Chapter 4 Electrical Specifications* : Includes the electrical characteristics for the scanner and timing sequences.
- ❖ *Chapter 5 External Reference Circuit* : Introduces the external reference circuit of the scanner.
- ❖ *Chapter 6 Auxiliary Tools* : Introduces useful tools you can use to set up the FM600.
- ❖ *Chapter 7 Configuration* : Introduces the use of programming barcodes and product information query.
- ❖ *Chapter 8 Communication Interface* : Describes how to configure RS-232 and USB communication parameters.
- ❖ *Chapter 9, System Settings* : Describes how to configure general parameters of the FM600.
- ❖ *Chapter 10 Symbologies* : Lists all compatible symbologies and describes how to configure the relevant parameters.
- ❖ *Chapter 10, Data Formatter* : Explains how to customize scanned data with the advanced data formatter.
- ❖ *Chapter 11, Prefix & Suffix* : Describes how to use prefix and suffix to customize scanned data.
- ❖ *Chapter 12 Programming Commands* : Introduces how to configure the FM600 by serial commands sent from the

-
- host.
 - ◇ *Chapter 13, Batch Programming* : Explains how to integrate a complex programming task into a single barcode.
 - ◇ *Chapter 14, JavaScript Development* : This chapter introduces the core operation of JavaScript in the FM600 device.
 - ◇ *Appendix* : Provides factory defaults table and a bunch of frequently used programming barcodes.

Explanation of Symbols

- This symbol indicates lists of required steps.
- ※ This symbol indicates notes of some parameters.

Explanation of Icons

| | |
|---|---|
|  | <p>This icon indicates auxiliary tools that help users to refer to the manual at ease.</p> |
|  | <p>This icon indicates this information requires extra attention from the reader.</p> |
|  | <p>This icon indicates handy tips that can help you use or configure the scanner with ease.</p> |
|  | <p>This icon indicates practical examples that can help you to acquaint yourself with operations.</p> |

Chapter 1 Getting Started

Introduction

The NLS-FM600 is a high-end fixed smart scanner designed for medical testing applications. It is primarily integrated into IVD automation instruments in laboratories, hospitals, and testing institutions, supporting visual recognition and high-performance barcode scanning during pre-processing or intermediate processing stages.



Note: This guide provides general instructions for the installation. Fujian Newland Auto-ID Tech. Co., Ltd. recommends an opto-mechanical engineer should conduct an opto-mechanical analysis before design.

Symbologies

The FM600 can easily read printed barcodes and on-screen barcodes, including:

| | |
|--------|---|
| 1D | Code 11, Code 128, Code 39, GS1 128 (UCC/EAN-128), AMI 128, Codabar, ISBT 128, Code 93, UPCA, UPCE, Coupon, GS1 Composite, EAN13, EAN8, ISSN, ISBN, Interleaved 2/5, Matrix 2/5, ITF14, ITF6, Industrial 2/5, Standard 2/5, China Post 25, MSI Plessey, Plessey, GS1 Databar (RSS), Code 49, Code 16K, Pharmacode, etc. |
| 2D | PDF417, QR Code, Data Matrix, Chinese Sensible Code, Micro PDF417, GM Code, Micro QR, Code One, etc. |
| Postal | USPS Postnet, USPS Intelligent Mail, Royal Mail, USPS Planet, KIX Post, Australian Postal, Japan Post |
| OCR | Supports letters and numbers in common fonts. |

Features

- **Optimized AI Solution**

The NLS-FM600 is equipped with a high-performance multi-core AI processing platform and advanced AI algorithms for parallel decoding, significantly boosting barcode reading speed and enhancing multi-code recognition capabilities.
- **Superior Scanning Performance**

Armed with Newland's seven-generation of **uimg**® technology, the scan engine can swiftly and effortlessly decode even poor quality barcodes (e.g., low contrast, laminated, damaged, torn, warped or wrinkled).
- **Ultra-Compact Design**

This miniature smart camera is easily integrated into various devices, making it perfect for space-constrained applications.
- **Multiple Interfaces**

It provides RS-232, Ethernet and USB interfaces to meet different needs.
- **Advanced OCR Recognition Technology**

Equipped with self-developed OCR technology, the NLS-FM600 seamlessly recognizes a wide range of English text and numbers, including dates, batch numbers, and phone numbers. It also supports simultaneous recognition of both barcodes and OCR.
- **2.3 Megapixel CMOS**

Thanks to its 2.3MP resolution CMOS sensor, the NLS-FM600 is able to capture high resolution images and decode barcode over a larger field of view.
- **Adjustable Focus**

Manually adjust the focus by rotating the knob to achieve the sharpest imaging results, enabling flexible depth-of-field settings.
- **IP65-Sealed Housing**

The housing is sealed to an IP65 rating, durable and secure.
- **Dual Aimers**

With two green LED aimers, accurately and automatically focus on the target to take the shot.

Components

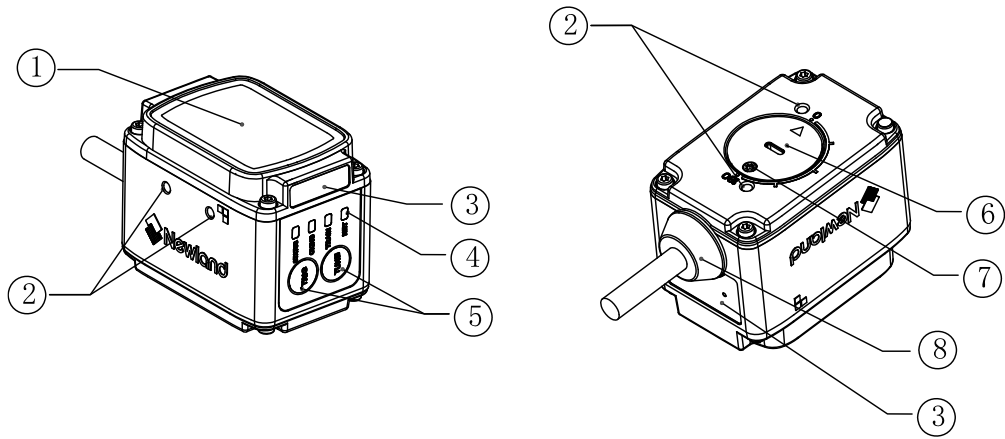

- ① Scan Window ② Mounting Hole ③ Label ④ LED. ⑤ Button ⑥ Focus Knob ⑦ Focus Lock Screw ⑧ Cable

Figure 1-1

Chapter 2 Installation

Introduction

This chapter explains how to install the FM600, including its structure and optical & electrical considerations during the installation process.



Caution: Do not touch the imaging lens when installing or moving the scanner. Be careful not to leave fingerprints on the lens.



Caution: Do not disassemble the product without authorization, as it may cause damage.

Dimensions (unit: mm)

Without cable: 37(W)×55.5(D)×42.5(H) (max.) (without cable)

Mounting

The illustrations below show the mechanical mounting dimensions (unit: mm) for the FM600.

Front View:



Figure 2-1

Side View

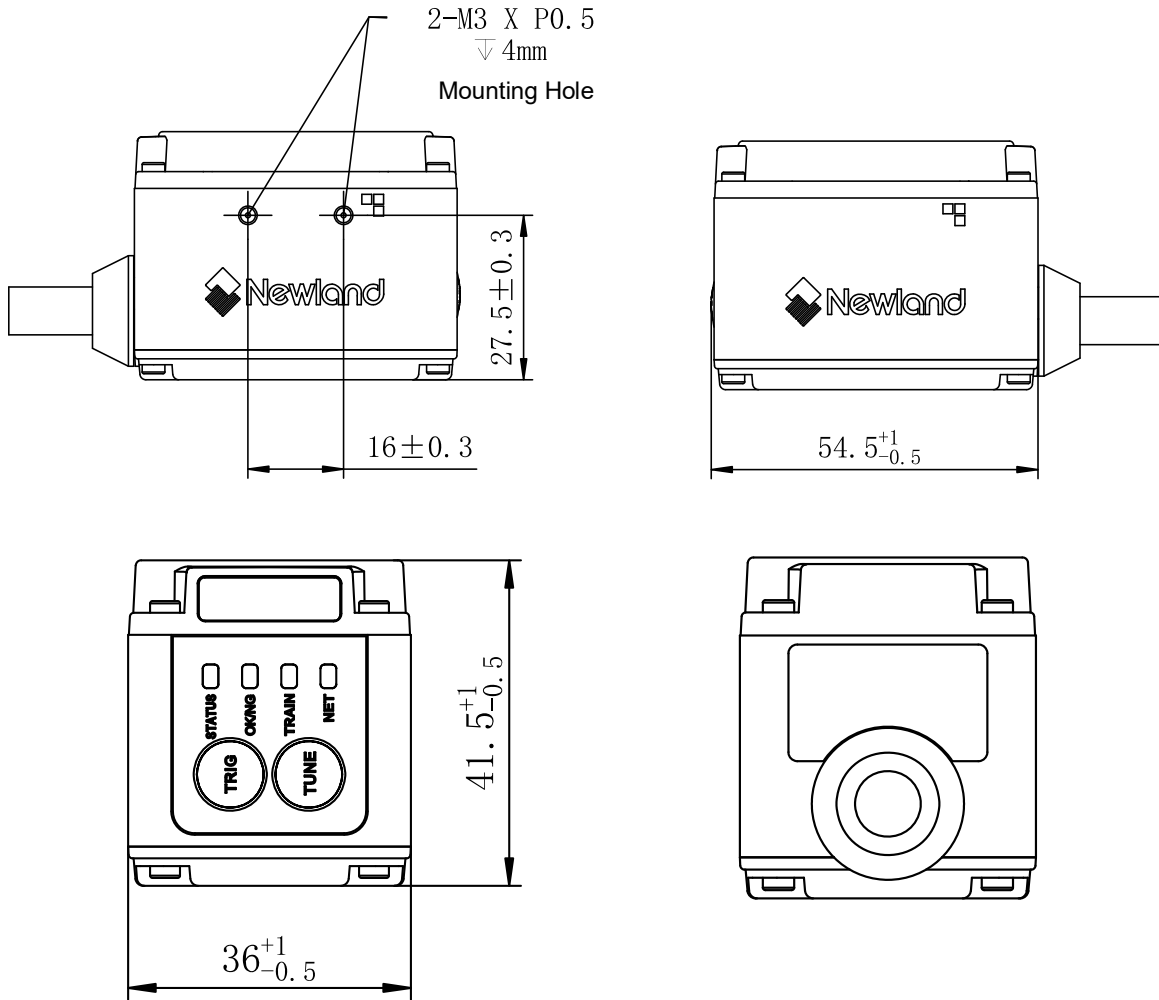

Figure 2-2

Bottom View







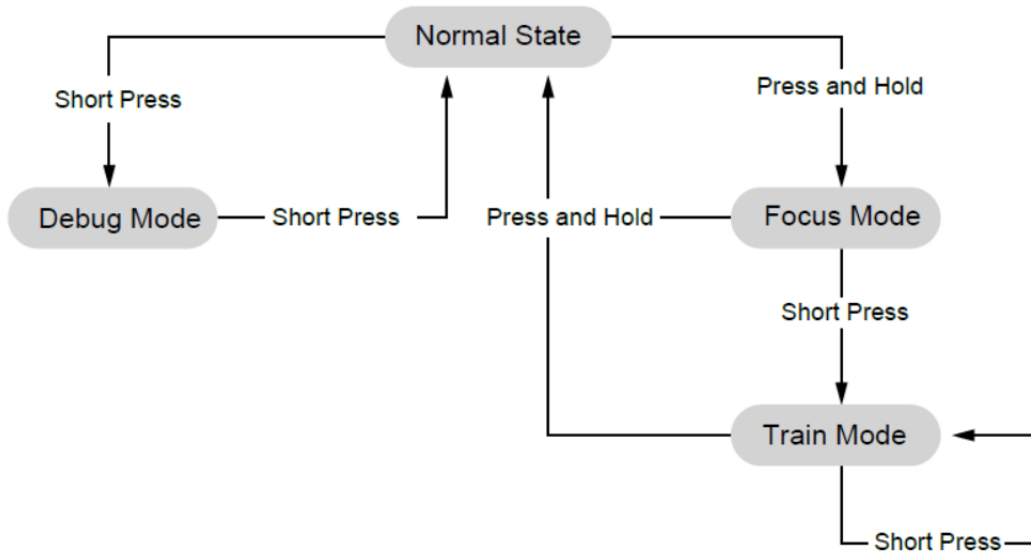

Figure 2-3

Button Functions

TUNE Button Function



| | | |
|----------------------------|---|--|
| <p>Normal State</p> | <p>After the device is successfully powered on, it enters the normal state. In this state, the device can scan barcodes, respond to switch operations, and execute valid commands sent by the host device.</p> |  <p>Normal State</p> |
| <p>Debug Mode</p> | <p>In the normal state, short press the TUNE button once to enter the debug mode. The STATUS LED will remain solid yellow, and the device will continuously scan and upload the real-time good read rate. Short press the TUNE switch once again to exit the debug mode.</p> |  <p>Debug Mode</p> |
| <p>Focus Mode</p> | <p>In the normal state, press and hold the TUNE button for about 3 seconds to enter focus mode. The TRAIN LED will remain solid yellow, and the OK/NG LED will remain solid red by default. Rotate the focus knob to adjust the focus.</p> <ul style="list-style-type: none"> • If focusing fails, the OK/NG LED will remain solid red. • If focusing is successful, the OK/NG LED will remain solid green. |  <p>Focusing Process</p>  <p>Focusing Success</p> |

| | | |
|--|--|---|
| <p>Train Mode</p> | <p>In focus mode, press the TUNE button once to enter train mode. The TRAIN LED will flash yellow, and the illumination led will flash.</p> <p>During the training process, press the TUNE button once to stop training, and press it again to restart the training.</p> <ul style="list-style-type: none"> • If training is successful, the TRAIN LED will remain solid green, and the device will save the current optical configuration (it will not be lost when powered off). • If training fails or is stopped, the TRAIN LED will remain solid red. Regardless of whether the training is successful or failed, the device will automatically enter a continuous scanning mode and upload the real-time good read rate. |  <p>In Training</p> <p>Training Success</p> <p>Training Failed</p> |
| <p> Note: In both debug mode and train mode, press and hold the TUNE button for 3 seconds at any time will return the device to normal mode.</p> | | |

TRIG Button Function

Press the TRIG button to start scanning; release the TRIG button to stop scanning.

| | | |
|----------------------|--|--|
| <p>Factory Reset</p> | <p>Press and hold both the TUNE and TRIG buttons while powering on the device. Hold for approximately 5 seconds until all LED indicators turn yellow simultaneously, and the device emits a long beep. Release the buttons, and the device will restart and restore to factory settings.</p> |  <p>Factory Reset</p> |
|----------------------|--|--|

Lens Cover

The device comes with two lens cover accessories by default: one pre-installed (polarizer) and another included in the packaging (high transmittance). If the fill light is not required in the actual usage environment, we recommend using the high transmittance lens cover.

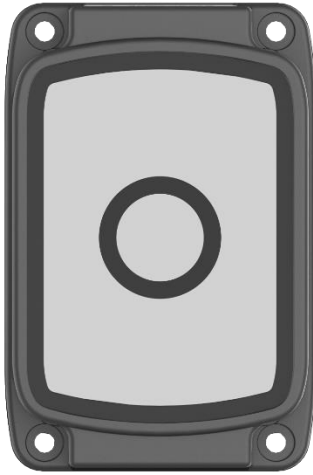

Polarizer cover (default)

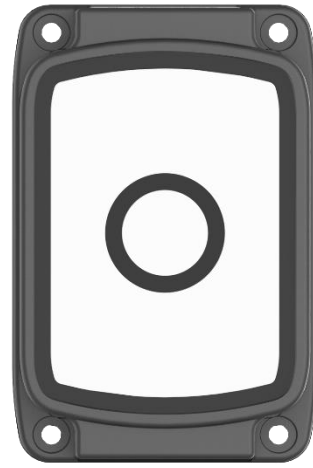

High transmittance cover

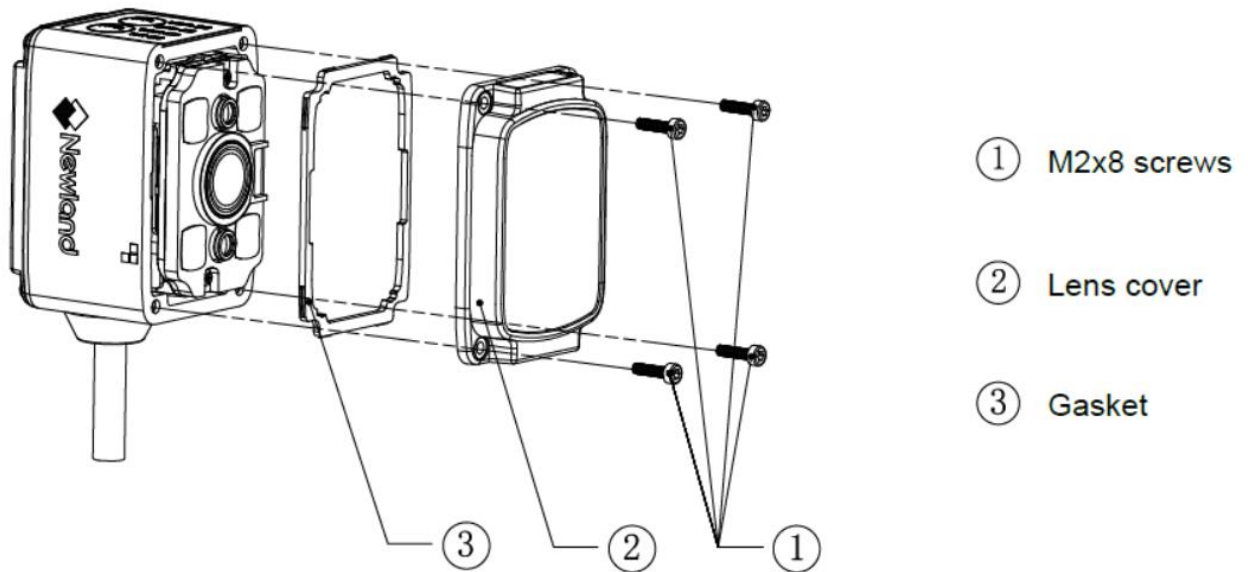

Lens Cover Replacement

1. Remove the four screws from the lens cover using a T5 screwdriver.
2. Remove the original lens cover and gasket.
3. Inspect the replacement lens cover to ensure it is free from oil, dust, or foreign matter. If necessary, clean with a lint-free cloth or compressed air.
4. Install the gasket onto the lens cover, then attach them to the device.
5. Secure the lens cover with the four provided M2x8 screws, tightening them with a T5 screwdriver. Ensure the tightening torque does not exceed 0.2 N·m.

Note: The replacement process should be performed in a dust-free, dry environment to prevent dust contamination of the imaging system during assembly.

-
- The Polarizer Lens Cover parameters can be configured by scanning the following barcodes or sending related commands.



@SETUPE1

【Enter Setup】



@BATCHS

【Enable Batch Barcode】



@EXPEMN800;EXPEMX800;ILLSCN1;EXPLUM80;

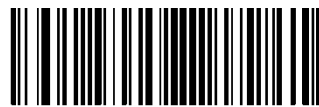

@SETUPE0

【Exit Setup】

-
- The High Transmittance Lens Cover parameters can be configured by scanning the following barcodes or sending related commands.



@SETUP1

【Enter Setup】



@BATCHS

【Enable Batch Barcode】

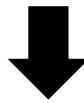

@EXPXM30000;EXPXMN2000;ILLSCN0;EXPLUM40;



@SETUP0

【Exit Setup】

Focus Adjust

Scan View

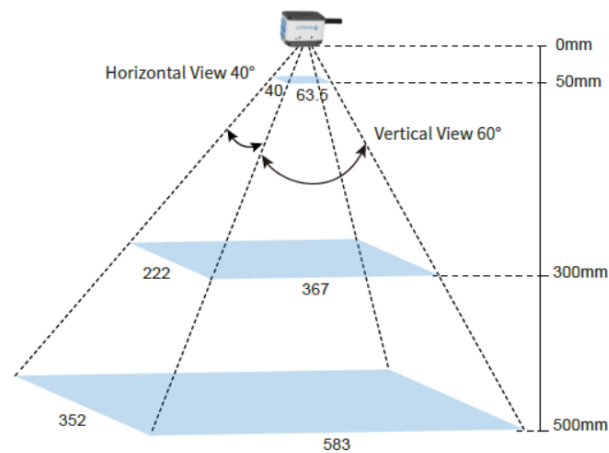

Focus Adjustment

1. Position the Device and Calibration Grid

Place the calibration grid at the target distance in front of the device, ensuring that the distance falls within the nearest and farthest range indicated in the device's field of view. The device should be aligned with the center of the calibration grid.

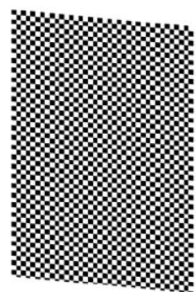

Horizontal

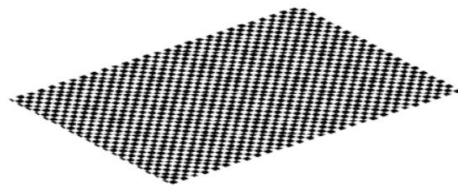

Vertical



Note: During the focusing process, both the device and the calibration grid must remain stationary. Any movement may affect focusing accuracy and could lead to focusing failure.

2. Entering Focus Mode

The device can be entered into focus mode using any of the following methods:

- Press and hold the "TUNE" button.
- Scan the focus setup barcode.
- Use the configuration utility.

3. Loosen the Focus Lock Screw

| | |
|---|---|
|  | <p>Use a Phillips screwdriver (PH0) to turn the focus lock screw counterclockwise.</p> <p> Note: Do not loosen the screw excessively to avoid it falling out.</p> |
|---|---|

4. Rotate the Focus Knob to 180

| | |
|---|--|
|  | <p>Use a flathead screwdriver (SL4.0) to slowly turn the focus knob clockwise until the arrow on the knob points to 180.</p> |
|---|--|

5. Rotate the Focus Knob and Monitor the Indicator Light

| | |
|---|---|
|  | <p>Using a flathead screwdriver (SL4.0), slowly rotate the focus knob counterclockwise. Monitor the OK/NG LED indicator:</p> <ul style="list-style-type: none">● Focusing Success: Green LED is solid on.● Focusing Failed: If the arrow reaches 0 and the OK/NG LED indicator remains red, the focus has failed. Press and hold the "TUNE" switch for 3 seconds to exit focus mode, then repeat steps 1 to 5. |
|---|---|

6. Tighten the Focus Lock Screw



7. Exit Focus Mode

Press and hold the "TUNE" button, scan the exit setup barcode, or use the Nset app to exit focus mode.

External Interface

The FM600 features a four-way external cable, providing RS-232, USB, and 10/100 Mbps Ethernet interfaces for host communication and power supply. External connections include DuPont connectors, USB-A ports, Ethernet RJ45 connectors, and a DC power input. Refer to Table 4-1 for the pin definitions of the DuPont connector wiring sequence.

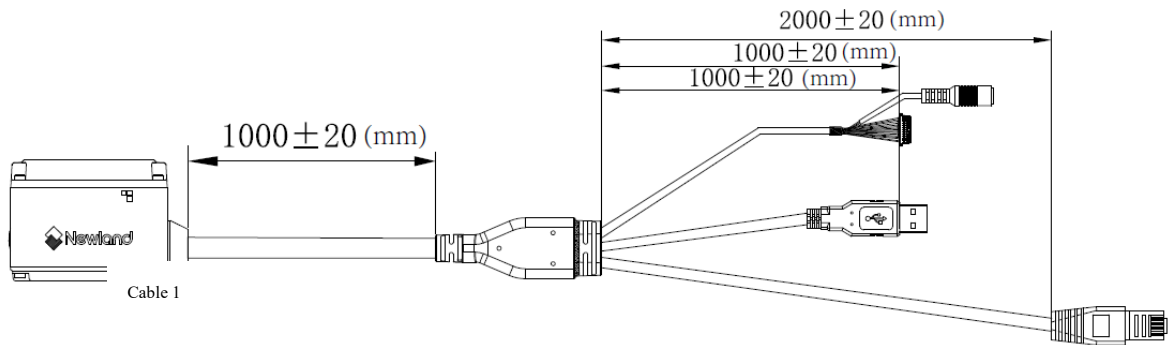
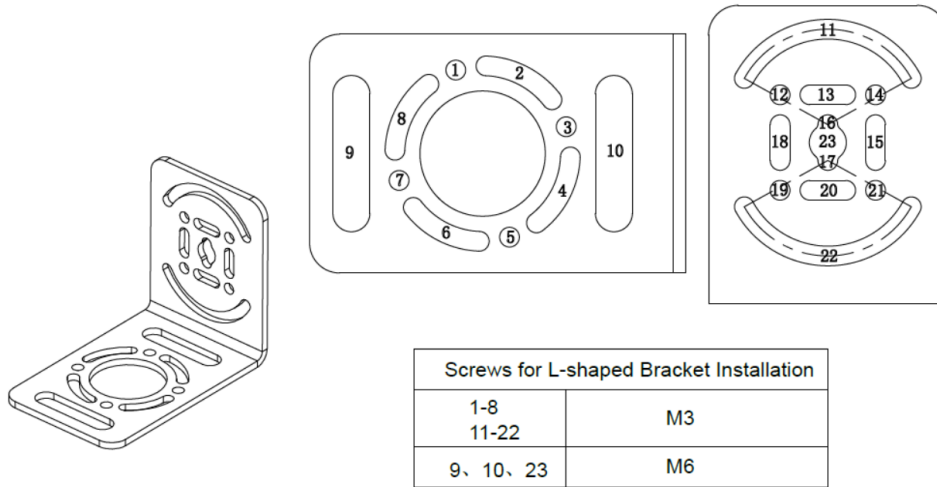

Figure 2-5

Bracket

L-shaped Bracket



Bracket Installation

1. Attach the L-shaped bracket to the device using the four provided M3x8 screws, and tighten them with a PH1 screwdriver. The tightening torque should not exceed 0.4 N·m.
2. The mounting hole locations shown above are for reference only. Please choose the appropriate holes on the bracket to install the device according to your needs.

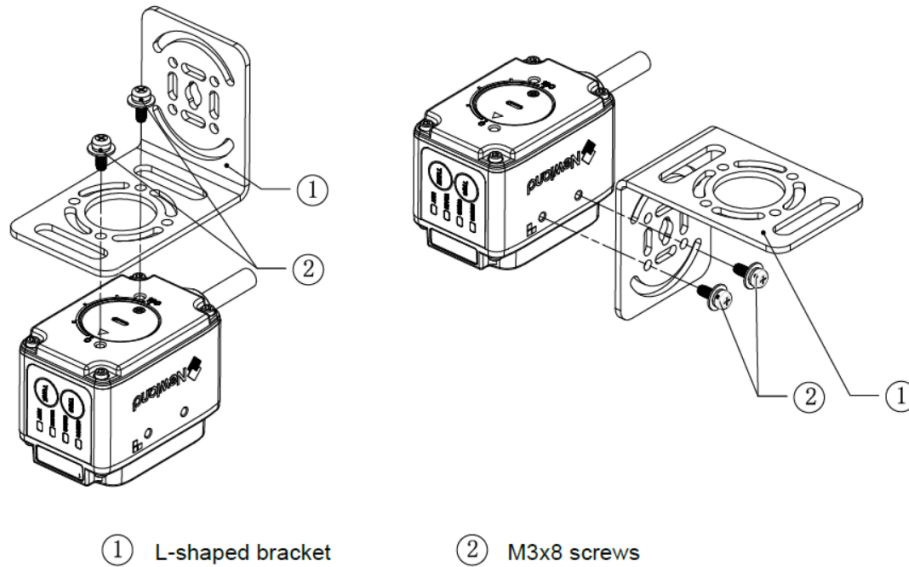

ESD

The FM600 incorporates ESD protection rated for ± 8 kV contact discharge and ± 14 kV air discharge. During unpacking and operation, ESD control measures must be applied, including the use of grounded wrist straps and properly grounded work surfaces. Due to the module's compact design, clients are required to enhance ESD protection in their application environments.

Precaution

1. Use only the power supply defined in the FM600 datasheet. Otherwise, there is a risk of damage to the device.
 2. Keep the cables away from high-tension cables or power sources. Otherwise, noise could cause malfunctions or accidents.
 3. Be sure to turn the power off to devices attached to the FM600 when you plug or unplug the cables. Failure to do so may cause damage to the FM600.
 4. Do not turn off the power during an upgrade, as this may cause internal data corruption.
 5. Do not disassemble or modify the FM600. Doing so may lead to damage on the unit.
 6. The FM600 is a precision instrument. Do not apply shock to the instrument or drop it. Be especially careful when
-

transporting or installing the unit

7. Do not allow water, oil, dust, or other foreign substances to stick to the scanner. This may cause read errors.

8. Use a soft, dry cloth or a cloth dipped in alcohol to wipe any substances from the scanner.

Thermal Considerations

Electronic components in the FM600 will generate heat during the course of their operation. Operating the FM600 in continuous mode for an extended period may cause temperatures to rise on CPU, LEDs, DC-DC, etc. Overheating can degrade image quality and affect scanning performance. Given that, the following precautions should be taken into consideration when integrating the FM600.

- ✧ Reserve sufficient space for good air circulation in the design.
- ✧ Avoid wrapping the FM600 with thermal insulation materials such as rubber.
- ✧ Use high thermal conductivity insulating materials to transfer heat from the high-power components on the FM600 to the device shell or heat dissipation material.

Ambient Environment

The following environmental requirements should be met to ensure good performance of the FM600.

Table 2-1

| | |
|-----------------------|-------------------------------|
| Operating Temperature | -10°C to 45°C (14°F to 113°F) |
| Storage Temperature | -20°C to 70°C (-4°F to 158°F) |
| Humidity | 5%~95% (non-condensing) |
| Ambient Light | 0-100000lux |

Note:

Operating Temperature: Scan Mode=Level Trigger Mode, Reading Interval= 5s

Chapter 3 Optics

Introduction

The FM600 contains:

- a CMOS image sensor and its lens
- Four white LEDs based illumination system and one lens.
- two laser aimers

Sensor

Pixel: 1920x1200 Mono CMOS

Frame rate: 60fps

Illumination

The FM600 implements an array-type, fully symmetrical design featuring white LEDs meticulously aligned with the lens's optical parameters. This ensures expansive, uniform, and high-intensity illumination across the entire field of view.

The FM600 has four white LEDs for supplementary lighting, making it possible to scan barcodes even in complete darkness. The illumination can be programmed On or Off. Customers can add the external illumination system if needed. The spectral range should be within the visible light.

Aimer

The FM600 contains two laser aimers that produce aiming spot patterns. The center of dual laser spots should be aligned with the center of the barcode to help the user to easily position the target barcode. The aiming pattern can be turned On or Off. It is recommended to enable the aiming pattern in regular applications.



Laser Aiming Spot

Figure 3-1

LED Indicators



| LED Indicators | LED Status | Description |
|---|--------------------|--|
| STATUS | LED off | The device is powered off |
| | Green LED on | The device is powered on and enters the standby state. |
| | Yellow LED on | The device enters the debug mode |
| | Yellow LED flashes | Enter focus/ train mode |
| | Red LED on | It indicates device malfunction |
| | Red LED flashes | Device lost authorization |
| OK/NG | Green LED flashes | It indicates a good read. |
| | Red LED flashes | It indicates a bad read. |
| TRAIN | LED off | Run with default configuration |
| | Yellow LED on | The device is in focus mode |
| | Yellow LED flashes | In training |
| | Green LED on | Training successful and operating in train mode |
| | Red LED on | Training failed |
| NET | LED off | No network connection |
| | Green LED on | Network connection OK |
| All four LED indicators turn solid yellow: the device will restore to factory settings. | | |

Window Size

The window should be positioned properly to let the illumination and aiming beams pass through as much as possible and no reflections back into the scanner (reflections can degrade the reading performance of the scanner).

The window must not block the field of view and should be sized to accommodate the FOV envelope shown below.

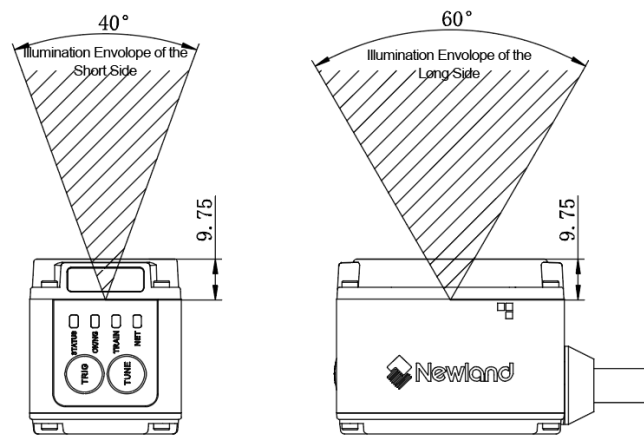

Figure 3-3

Ambient Light

The FM600 shows better performance with ambient light. However, high-frequency pulsed light can result in performance degradation.

Eye Safety

The FM600 uses LEDs to produce illumination beam. The LEDs are bright, but testing has been done to demonstrate that the scanner is safe for its intended application under normal usage conditions. The FM600 complies with IEC 62471:2006 for LED safety. However, the user should avoid looking into the beam.

Depth of Field

Scan View

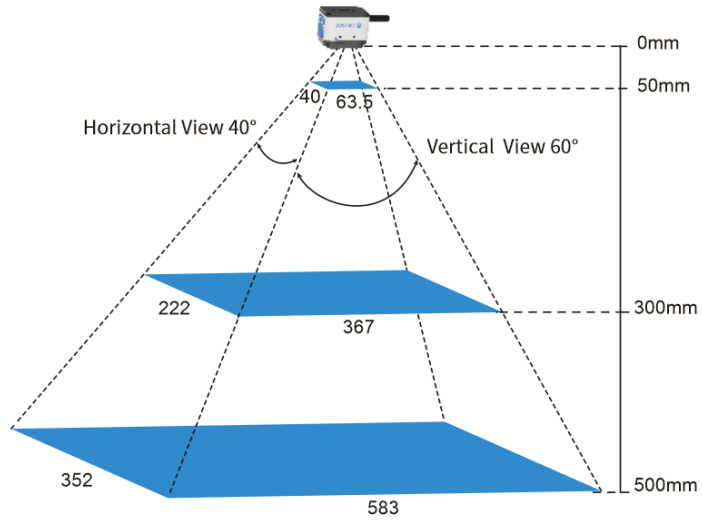

Reading Accuracy

| Barcode Type | Object Distance | Focus | Minimum Density |
|--------------|-----------------|-------|-----------------|
| Code39 | 50mm | 50mm | 3.3mil |
| | 240mm | 240mm | 5mil |
| | 330mm | 330mm | 6.7mil |
| | 500mm | 500mm | 10mil |
| QR | 95mm | 95mm | 5mil |
| | 260mm | 260mm | 10mil |
| | 400mm | 400mm | 15mil |
| | 540mm | 540mm | 20mil |

Depth of Field (DOF)

| | |
|--------------------|----------|
| Code 128 (6.63mil) | 55-370mm |
| Code 128 (10mil) | 45-520mm |
| QR Code (10mil) | 55-270mm |
| QR Code (15mil) | 30-410mm |

Note:

1. The above DOF parameters correspond to the factory default focus setting. Changing the focal length changes the parameters. Can adjust focal length based on the actual usage.
2. The above DOF parameters are for reference only. Different barcodes and installation angles may affect the parameters. Final parameters should be based on actual usage.
3. DOF parameters Test condition: T=23°C ; Illumination=300lux using incandescent lamp; sample barcodes made by Newland.
4. The depth of field requirements can be met under both 0 lux and 300 lux lighting conditions.

Chapter 4 Electrical Specifications

Power Supply

Do not power up the FM600 until it is properly connected. Be sure the power is cut off before connecting a cable to or disconnecting a cable from the host interface connector. Hot-plugging could damage the scanner.

Unstable power supply or sharp voltage drops or unreasonably short interval between power-ons may lead to unstable performance of the scanner. Do not resupply the power immediately after cutting it off.



1. When designing, the user should ensure that the input power of FM600 is fully decoupled. It is recommended to place a 22uF and a 100nF X5R or X7R ceramic capacitor beside the power input pin on the connector which is soldered on the board.
2. Ensure that the input power drops below 0.5V before powering the FM600 on again, otherwise it will lead to abnormal function.
3. In order to ensure reliable operation, it is necessary to use a low-noise power supply. Pay attention to power quality and testing to ensure that the FM600 achieves optimal performance. Therefore, the ripple voltage of the power input to the FM600 module must not exceed $VCC * 5\%$.

Operating Requirements

1. Ensure the barcode scanner, data cable, host, and power supply are properly connected and powered on.
2. Place the barcode within the field of view and align it with the scan window. The illumination light will activate, and scanning will begin.
3. Once scanning is successful, the device will transmit the data to the host.

Note: During installation, adjust the scanning area to the position where the image is sharpest.

12-pin Dupont Interface

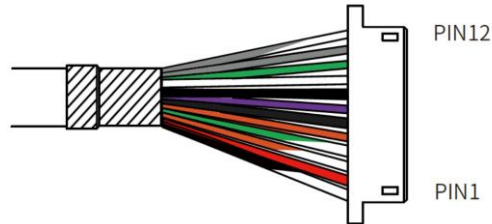

Male connector model molex510211200, recommended female connector model molex53047-1210.

12-pin Dupont Interface Pinouts

| PIN# | Wire Color | Signal | I/O | Description |
|------|----------------|-----------|-----|---|
| 1 | Black-White | COM_G | P | All SW_IN and SW_OUT Pins External Isolated Reference Ground |
| 2 | Red | 24VDC | P | Power Input |
| 3 | Orange-White | SW_IN_1 | I | Control Input |
| 4 | Green-White | SW_OUT_1 | O | Switch Output |
| 5 | Orange | SW_IN_0 | I | Control Input |
| 6 | Black | SW_OUT_0 | O | Switch Output |
| 7 | Purple | GND | P | Power Supply - Ground |
| 8 | Black (Shield) | FE/Shield | - | Power Supply - Ground |
| 9 | White | RS232 RXD | I | Serial Input |
| 10 | Green | RS232 TXD | O | Serial Output |
| 11 | Gray | NC | - | Reserved |
| 12 | Gray-White | NC | - | Reserved |

Table 4-1

※ I = Input; O = Output;

※ 1 The SW IN pin is used as trigger signal. A trigger pull activates a decode session. The decode session continues until a barcode is decoded or you release the trigger.

For the external switching input circuit, please see the “Switching Input Circuit” section in Chapter 5.

For more details, please see the “Switching Input Signal” section in Chapter 9.

※ 2 The SW OUT pin is reserved as external switching output signal. If this pin is not used, leave it unconnected. It produces high level (duration: 400ms) after a barcode is decoded.

For the external switching output circuit, please see the “Switching Output Circuit” section in Chapter 5.

For more details, please see the “Switching Output Signal” section in Chapter 9.

DC Interface

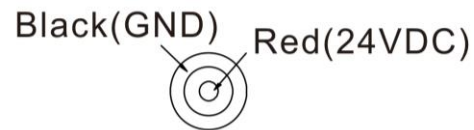

DC Jack: 5.5*2.1*17.5mm

USB Interface

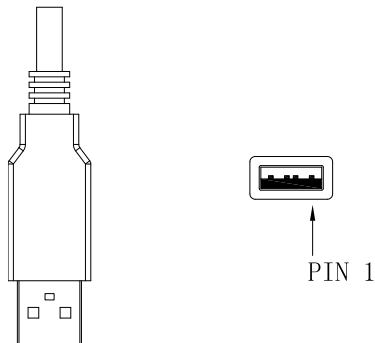

| PIN# | Signal | Type | Description |
|------|--------|------|---|
| 1 | -- | -- | -- |
| 2 | USB_D- | A | Differential Data Signal for the USB interface (supports USB 1.1/USB 2.0, software configurable) |
| 3 | USB_D+ | A | |
| 4 | GND | P | Ground |

To ensure stable data transfer, please use host device with USB 3.0 interfaces when transmitting USB data

RJ45 Interface

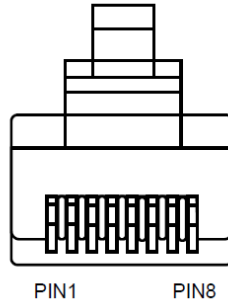

RJ45 Interface Pinouts

| PIN# | Wire Color | Signal | I/O | Description |
|------|-------------|----------|-----|------------------------|
| 1 | Brown | RJ45_TX+ | O | Transmit Data + Signal |
| 2 | Brown/White | RJ45_TX- | O | Transmit Data - Signal |
| 3 | Blue | RJ45_RX+ | I | Receive Data + Signal |
| 4 | -- | -- | -- | |
| 5 | -- | -- | -- | |
| 6 | Blue/White | RJ45_RX- | I | Receive Data - Signal |
| 7 | -- | -- | -- | |
| 8 | -- | -- | -- | |

DC Characteristics

Operating Voltage

Table 4-2

T=25°C

| Parameter | Description | Minimum | Typical | Maximum | Unit |
|-----------|-------------------------------------|------------------|---------|---------|------|
| VCC | Input Voltage $\pm 5\%$ (12-36V DC) | 18 ^{*1} | 24 | 36 | V |

※ 1: 12V is only used when the device uses external lighting. When the device uses its own lighting, the input voltage must be $\geq 18V$ and the current $\geq 1.5A$.

Operating Current

Table 4-3

T=25°C

| Mode | Typical | Maximum | Unit |
|-------------------|---------|---------|------|
| Operating Current | 466 | 973 | mA |
| Idle Current | / | 87 | mA |

I/O Voltage

SW_IN Input Signal

Table 4-4

18~36V, GND=0V, T=25°C

Note: The internal series resistance is 2.5K.

| Parameter | Description | Minimum | Typical | Maximum | Unit |
|-------------------|--------------------|---------|---------|---------|------|
| VIL | input low Voltage | 0 | 0 | 0.8 | V |
| VIH | input high Voltage | 9 | 24 | 24 | V |
| I _{in} ※ | input current | 3 | / | 10 | mA |

SW_IN Output Signal

Table 4-5

VCC<36V, I<50mA, T=25°C

| Parameter | Description | Minimum | Typical | Maximum | Unit |
|---------------------|---------------------|---------|---------|---------|------|
| VOL | Output low Voltage | 0 | 0.7 | 0.8 | V |
| VOH | Output high Voltage | 3 | VCC | 36※1 | V |
| I _{out} ※1 | Output current | / | / | 50 | mA |

Note: The output high voltage is determined by the external pull-up voltage, which should not exceed 36V. The device has no internal current-limiting resistor, so a proper pull-up resistor must be designed to ensure the load current is less than 50mA; otherwise, the device may be damaged.

Chapter 5 External Reference Circuit

External Circuit Design

Switch Output Circuit

Figure 5-1 provides an external circuit reference design for the switch output function. This pin currently has no practical function and is only used as a reserved interface for external output. It is primarily used to allow the FM600 to output high and low levels externally. The following reference design can be used in the application: the SW_OUT signal comes from the black and green-white signal wires of the 12-pin Dupont connector. The voltage depends on the specific application scenario, with a maximum voltage of 36V and a maximum current of 50mA.

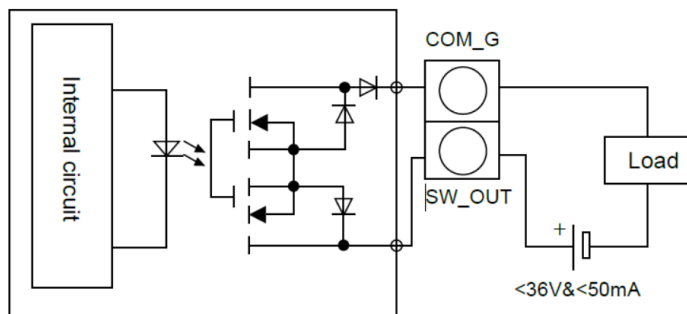

Figure 5-1

Control Input Circuit

Figure 5-2 provides a reference circuit design for the trigger function, which is used to supply a valid control input signal level to the FM600, enabling it to perform the corresponding action. The following reference design can be used in the application: connect the SW_IN signal to the orange or orange-white wire of the 12-pin DuPont connector (Note: A 2.5K resistor is connected in series. Choose an appropriate pull-up resistor based on the power supply to ensure the current meets the required specifications).

The default state of the SW_IN pin is: enable the low level and high level switch input.

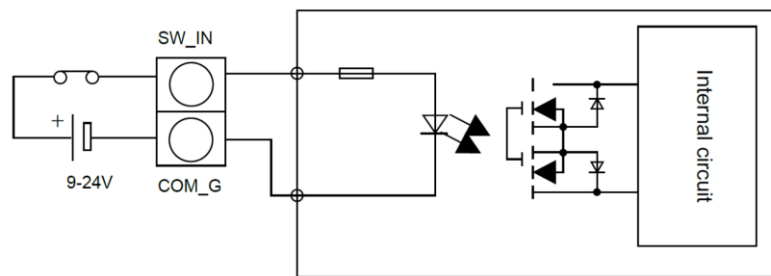

Figure 5-2

Chapter 6 Auxiliary Tools

Introduction

The FM600 is equipped with hardware and software auxiliary tools to support rapid application development. These tools serve the dual purpose of meeting the needs for quick evaluation and development, as well as facilitating rapid configuration and deployment for specific applications.

NSet

The NSet Setup Tool is a user interface client application developed by Fujian Newland Auto-ID Tech. Co., Ltd. It simplifies the initial setup and parameter adjustments of the scanners you use. The NSet serves as a common platform across all models. It is installed on and runs on Windows-based PCs (usually laptops), and connections are made through various interfaces. Its main features include:

- Online device management: Obtain device information, set parameters, and interact with devices.
- Configuration barcode generation: Can be printed or saved to PDF or Word documents.
- Device imaging: View real-time images and save them.
- Real-time device status monitoring: Keep track of the status of online devices.
- Command-based interaction: Communicate with devices using specific commands.
- XML configuration file modification: Add new commands or delete existing ones.

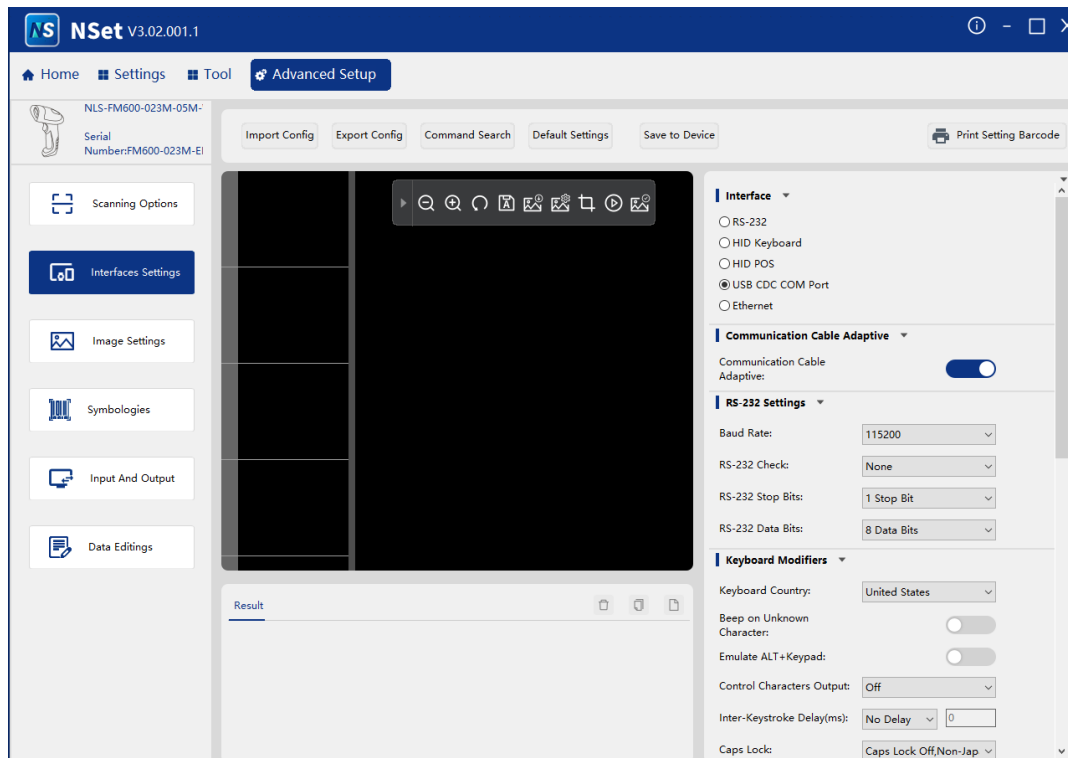

UFCOM

UFCOM, developed by Fujian Newland Auto-ID Tech. Co., Ltd., is a virtual serial driver. It is used in conjunction with a USB scanner or a scan engine configured as virtual serial port to provide two-way communication between the device and the host. UFCOM can run on all versions of Windows XP ~ Windows 10 x86 & x64, including the contemporary versions of Windows Server. Users can download the driver from the website at: <http://down.nlscan.com:82/Release/UFCOM/>.

Chapter 7 Configuration

Introduction

There are three ways to configure the FM600: Barcode programming, command programming and NSet programming.

Barcode Programming

The FM600 can be configured by scanning programming barcodes. All user programmable features/options are described along with their programming barcodes/commands in the following sections.

This programming method is most straightforward. However, it requires manually scanning barcodes. As a result, errors are more likely to occur.

Command Programming

The FM600 can also be configured by serial commands sent from the host device.

Users can design an application program to send those command strings to the scanners to perform device configuration.

NSet Programming

Besides the two methods mentioned above, you can conveniently perform scanner configuration through NSet too. NSet is a Windows-based configuration tool particularly designed for Newland products, enabling users to gain access to decoded data and captured images and to configure scanners.

Note: Some temporary settings will be lost upon device restart or power loss. All other configuration are saved in the scanner and will not be affected by shutdown.

Programming Barcode/ Programming Command/Function



The figure above is an example that shows you the programming barcode and command for the Enter Setup function:

1. The **No Case Conversion** barcode.
2. The **No Case Conversion** command.
3. The description of feature/option.

Use of Programming Barcodes

Scanning the **Enter Setup** barcode can enable the scanner to enter the setup mode. Then you can scan a number of programming barcodes to configure your scanner. To exit the setup mode, scan the **Exit Setup** barcode or a non-programming barcode, or reboot the scanner.



@SETUPE0

Exit Setup

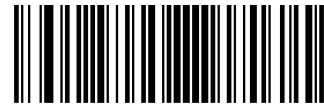

@SETUPE1

Enter Setup

Programming barcode data (i.e. the characters under programming barcode) can be transmitted to the host device. Scan the appropriate barcode below to enable or disable the transmission of programming barcode data to the host device.

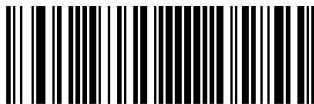

@SETUPT0

Do Not Transmit Programming Barcode Data



@SETUPT1

Transmit Programming Barcode Data

Default Settings

Factory Defaults

Scanning the following barcode can restore the scanner to the factory defaults.

You may need to reset all parameters to the factory defaults when:

- ✧ scanner is not properly configured so that it fails to decode barcodes.
- ✧ you forget previous configuration and want to avoid its impact.



Restore All Factory Defaults

Query Product Information

After scanning the barcode below, the product information (including product name, firmware version, decoder version, hardware version, serial number, OEM serial number and manufacturing date) will be sent to the host device.



@QRYSYS

Query Product Information

Query Product Name



@QRYPDN

Query Product Name

Query Firmware Version



@QRYFWW

Query Firmware Version

Query Hardware Version



@QRYHWW

Query Hardware Version

Query Product Serial Number



@QRYPSN

Query Product Serial Number

Query Manufacturing Date



@QRYDAT

Query Manufacturing Date

Query OEM Serial Number



@QRYESN

Query OEM Serial Number

Chapter 8 Communication Interface

Introduction

- ✧ Serial communication interface is usually used when connecting the scanner to a host device (like PC, POS). You need to set communication parameters to match the host device.
- ✧ USB HID Keyboard: The scanner's transmission is simulated as USB keyboard input with no need for command configuration or a driver. Barcode data could be entered by the virtual keyboard directly and it is also convenient for the host device to receive data.
- ✧ USB CDC: It is compliant with the standard USB CDC class specifications defined by the USB-IF and allows the host device to receive data in the way as a serial port does. A driver is needed when using this feature. User can download it from: <http://www.nlscan.com/supportList.aspx?p=1&type=3&key=uf> .
- ✧ HID POS (POS HID Barcode Scanner): It is based on the HID interface, with no need for a custom driver. It excels virtual keyboard and traditional TTL-232 interface in transmission speed.
- ✧ Ethernet: Connects devices to the host via an Ethernet communication interface. When utilizing the Ethernet communication interface, it is imperative that the scanner and the host device are fully matched in terms of communication parameter configuration to ensure smooth and accurate communication.

Adaptive Wired Communication

Disabled: The scanner communicates with the host based on the configured interface settings.

Enabled: The scanner automatically detects the connected cable type (USB or serial) and switches to the corresponding communication mode:

- USB mode when a USB cable is connected.
- Serial (RS-232) mode when a serial cable is connected.
- To enable both USB and serial communication, enable the RS-232 output channel in the output settings.

By default, the scanner supports multi-channel operation. It can still output data even when the configured communication interface (e.g., Ethernet) differs from the actual connection (e.g., USB).

Note: Restart the device for the changes to take effect.

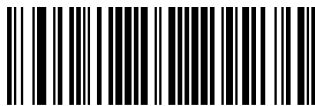

Off



On

When the scanner is connected to the host via both USB and serial (RS-232) interfaces simultaneously:

- If Adaptive Wired Communication is enabled, the scanner will prioritize USB communication over serial due to its higher protocol priority.
- If the configured communication interface is set to Serial (RS-232) but a USB cable is connected, the scanner will automatically switch to USB CDC mode.

RS-232 Interface

Serial communication interface is usually used when connecting the scanner to a host device (like PC, POS). However, to ensure smooth communication and accuracy of data, you need to set communication parameters (including baud rate, parity check, data bit and stop bit) to match the host device.



Baud Rate

Baud rate is the number of bits of data transmitted per second. Set the baud rate to match the host requirements.



@232BAD8

115200



@232BAD7

57600



@232BAD6

38400



@232BAD5

19200



@232BAD4

14400



@232BAD3

9600



@232BAD2

4800



@232BAD0

1200



@232BAD1

2400

Parity Check

Set the parity type to match the host requirements.

Odd Parity: If the data contains an odd number of 1 bits, the parity bit value is set to 0.

Even Parity: If the data contains an even number of 1 bits, the parity bit value is set to 0.

None: Select this option when no parity bit is required.



@232PAR0

None



@232PAR1

Even Parity



@232PAR2

Odd Parity

Data Bit

Set the number of data bits to match the host requirements.



@232DAT1

7 Data Bits



@232DAT0

8 Data Bits

Stop Bit

The stop bit(s) at the end of each transmitted character marks the end of transmission of one character and prepares the receiving device for the next character in the serial data stream. Set the number of stop bits to match the host requirements.



@232STP0

1 Stop Bit



@232STP1

2 Stop Bits

USB HID Keyboard

When the scanner is connected to the USB port on a host device, you can enable the USB HID Keyboard feature by scanning the barcode below. Then scanner's transmission will be simulated as USB keyboard input. The Host receives keystrokes on the virtual keyboard. It works on a Plug and Play basis and no driver is required.



@INTERF3

USB HID Keyboard



If the host device allows keyboard input, then no extra software is needed for HID Keyboard input.

USB Country Keyboard Types

Keyboard layouts vary from country to country. The default setting is U.S. keyboard.



@KBWCTY0
U.S. (English)



@KBWCTY1
Belgium



@KBWCTY2
Brazil



@KBWCTY3
Canada (French)



@KBWCTY4
Czechoslovakia



@KBWCTY5
Denmark



@KBWCTY6
Finland (Swedish)



@KBWCTY8

Germany/ Austria



@KBWCTY10

Hungary



@KBWCTY12

Italy



@KBWCTY14

Netherlands (Dutch)



@KBWCTY7

France



@KBWCTY9

Greece

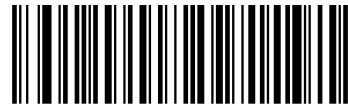

@KBWCTY11

Israel (Hebrew)

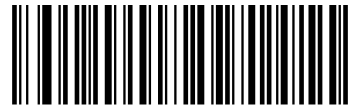

@KBWCTY13

Latin America/ South America



@KBWCTY16

Poland



@KBWCTY18

Romania



@KBWCTY21

Slovakia



@KBWCTY23

Sweden



@KBWCTY15

Norway



@KBWCTY17

Portugal



@KBWCTY19

Russia



@KBWCTY22

Spain



@KBWCTY25

Turkey_F



@KBWCTY27

UK



@KBWCTY37

Vietnam



@KBWCTY24

Switzerland (German)

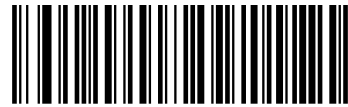

@KBWCTY26

Turkey_Q



@KBWCTY28

Japan

Beep on Unknown Character

Due to the differences in keyboard layouts, some characters contained in barcode data may be unavailable on the selected keyboard. As a result, the scanner fails to transmit the unknown characters.

Scan the appropriate barcode below to enable or disable the emission of beep when an unknown character is detected.



Do Not Beep on Unknown Character



Beep on Unknown Character



Supposing French keyboard (Country Code: 7) is selected and barcode data "ADF" is being dealt with, the keyboard will fail to locate the "Ð" (0xD0) character and the scanner will ignore the character and continue to process the next one.

Do Not Beep on Unknown Character: The scanner does not beep and the Host receives "AF".

Beep on Unknown Character: The scanner beeps and the Host still receives "AF".



If **Emulate ALT+Keypad ON** is selected, **Beep on Unknown Character** does not function.

Emulate ALT+Keypad

When **Emulate ALT+Keypad** is turned on, ASCII characters (0x20 - 0xFF) are sent over the numeric keypad no matter which keyboard type is selected.

1. ALT Make
2. Enter the number corresponding to a desired character on the keypad.
3. ALT Break

After **Emulate ALT+Keypad ON** is selected, you need to choose the code page with which the barcodes were created and to turn **Unicode Encoding** On or Off depending on the encoding used by the application software.

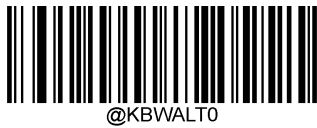

Emulate ALT+Keypad OFF

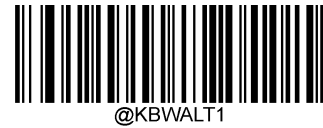

Emulate ALT+Keypad ON



Since sending a character involves multiple keystroke emulations, this method appears less efficient.



Supposing **Emulate ALT+Keypad** is ON, **Unicode Encoding** is Off, **Code Page 1252 (West European Latin)** is selected, and **Emulate Keypad with Leading Zero** is Off, barcode data "ADF" (65/208/70) is sent as below:

"A" -- "ALT Make" + "065" + "ALT Break"

"D" -- "ALT Make" + "208" + "ALT Break"

"F" -- "ALT Make" + "070" + "ALT Break"

Code Page

Code pages define the mapping of character codes to characters. If the data received does not display with the proper characters, it may be because the barcode being scanned was created using a code page that is different from the one the host program is expecting. If this is the case, select the code page with which the barcodes were created by scanning the appropriate barcode below. For PDF417, QR Code and Data Matrix, besides setting the code page, you also need to set the character encoding in the “Character Encoding” section in Chapter 6. This feature is only effective when **Emulate ALT+Keypad** is turned on.



@KBWCPG0

Code Page 1252 (West European Latin)



@KBWCPG2

Code Page 1250 (Central and East European Latin)



@KBWCPG4

Code Page 1254 (Turkish)

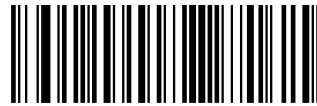

@KBWCPG1

Code Page 1251 (Cyrillic)



@KBWCPG3

Code Page 1253 (Greek)



@KBWCPG5

Code Page 1255 (Hebrew)



@KBWCPG6

Code Page 1256 (Arabic)



@KBWCPG7

Code Page 1257 (Baltic)



@KBWCPG8

Code Page 1258 (Vietnamese)



@KBWCPG9

Code Page 936 (Simplified Chinese, GB2312,GBK)



@KBWCPG10

Code Page 950 (Traditional Chinese, Big5)



@KBWCPG11

Code Page 874 (Thai)



@KBWCPG12

Code Page 932 (Japanese, Shift-JIS)

Unicode Encoding

Different host program may use different character encodings for handling incoming barcode data. For instance, Microsoft Office Word uses Unicode encoding and therefore you should turn **Unicode Encoding** on, whereas Microsoft Office Excel or Notepad uses Code Page encoding and therefore you should turn **Unicode Encoding** off. This feature is only effective when **Emulate ALT+Keypad** is turned on.

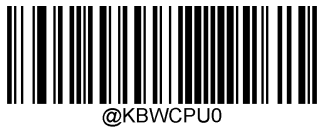

Off

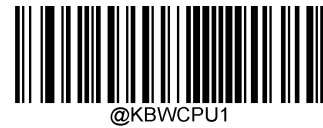

On

Emulate Keypad with Leading Zero

You may turn this feature on to send character sequences sent over the numeric keypad as ISO characters which have a leading zero. For example, ASCII A transmits as "ALT MAKE" 0065 "ALT BREAK". This feature is only effective when **Emulate ALT+Keypad** is enabled.



On



Off

Function Key Mapping

When **Ctrl+ASCII Mode** is selected, function characters (0x00 - 0x1F) are sent as ASCII sequences.



@KBWFKM0

Disable



@KBWFKM1

Ctrl+ASCII Mode



@KBWFKM2

Alt+Keypad Mode



If **Ctrl+ASCII Mode** is selected and other parameters of USB HID Keyboard adopt factory defaults, barcode data “A<HT>(i.e. Horizontal Tab)F” (0x41/0x09/0x46) is sent as below:

“A” - Keystroke “A”.

<HT> - “Ctrl Make” + Keystroke “I” + “Ctrl Break”

“F” - Keystroke “F”

For some text editors, “Ctrl I” means italic convert. So the output may be “*A*”.

If **Alt+Keypad Mode** is selected and other parameters of USB HID Keyboard adopt factory defaults, the data above is sent as below:

“A” - Keystroke “A”.

<HT> - “Alt Make” + Keystrokes “009” + “Alt Break”

“F” - Keystroke “F”

ASCII Function Key Mapping Table

| ASCII Function | ASCII Value (HEX) | Function Key Mapping Disabled | Ctrl+ASCII |
|----------------|-------------------|-------------------------------|------------|
| NUL | 00 | Null | Ctrl+@ |
| SOH | 01 | Keypad Enter | Ctrl+A |
| STX | 02 | Caps Lock | Ctrl+B |
| ETX | 03 | ALT | Ctrl+C |
| EOT | 04 | Null | Ctrl+D |
| ENQ | 05 | CTRL | Ctrl+E |
| ACK | 06 | Null | Ctrl+F |
| BEL | 07 | Enter | Ctrl+G |
| BS | 08 | Left Arrow | Ctrl+H |
| HT | 09 | Horizontal Tab | Ctrl+I |
| LF | 0A | Down Arrow | Ctrl+J |
| VT | 0B | Vertical Tab | Ctrl+K |
| FF | 0C | Delete | Ctrl+L |
| CR | 0D | Enter | Ctrl+M |
| SO | 0E | Insert | Ctrl+N |
| SI | 0F | Esc | Ctrl+O |
| DLE | 10 | F11 | Ctrl+P |
| DC1 | 11 | Home | Ctrl+Q |
| DC2 | 12 | Print Screen | Ctrl+R |
| DC3 | 13 | Backspace | Ctrl+S |
| DC4 | 14 | tab+shift | Ctrl+T |
| NAK | 15 | F12 | Ctrl+U |
| SYN | 16 | F1 | Ctrl+V |
| ETB | 17 | F2 | Ctrl+W |
| CAN | 18 | F3 | Ctrl+X |
| EM | 19 | F4 | Ctrl+Y |
| SUB | 1A | F5 | Ctrl+Z |
| ESC | 1B | F6 | Ctrl+[|
| FS | 1C | F7 | Ctrl+\ |
| GS | 1D | F8 | Ctrl+] |
| RS | 1E | F9 | Ctrl+6 |
| US | 1F | F10 | Ctrl+- |

ASCII Function Key Mapping Table (Continued)

The last five characters (0x1B~0x1F) in the table above apply to US keyboard layout only. The following chart provides the equivalents of these five characters for other countries.

| Country | Ctrl+ASCII | | | | | |
|----------------|------------|--------|---------|--------|--------|--|
| United States | Ctrl+[| Ctrl+\ | Ctrl+] | Ctrl+6 | Ctrl+- | |
| Belgium | Ctrl+[| Ctrl+< | Ctrl+] | Ctrl+6 | Ctrl+- | |
| Scandinavia | Ctrl+8 | Ctrl+< | Ctrl+9 | Ctrl+6 | Ctrl+- | |
| France | Ctrl+^ | Ctrl+8 | Ctrl+\$ | Ctrl+6 | Ctrl+= | |
| Germany | | Ctrl+Ã | Ctrl++ | Ctrl+6 | Ctrl+- | |
| Italy | | Ctrl+\ | Ctrl++ | Ctrl+6 | Ctrl+- | |
| Switzerland | | Ctrl+< | Ctrl+.. | Ctrl+6 | Ctrl+- | |
| United Kingdom | Ctrl+[| Ctrl+ø | Ctrl+] | Ctrl+6 | Ctrl+- | |
| Denmark | Ctrl+8 | Ctrl+\ | Ctrl+9 | Ctrl+6 | Ctrl+- | |
| Norway | Ctrl+8 | Ctrl+\ | Ctrl+9 | Ctrl+6 | Ctrl+- | |
| Spain | Ctrl+[| Ctrl+\ | Ctrl+] | Ctrl+6 | Ctrl+- | |

Inter-Keystroke Delay

This parameter specifies the delay between emulated keystrokes.



@KBWDLY0

No Delay



@KBWDLY40

Long Delay (40ms)

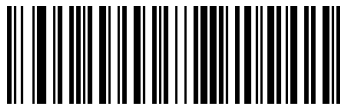

@KBWDLY20

Short Delay (20ms)



@KBWDLY

Custom Delay

Caps Lock

The **Caps Lock On** options can invert upper and lower case characters contained in barcode data. This inversion occurs regardless of the state of Caps Lock key on the host device's keyboard. To disable this feature, scan the appropriate **Caps Lock OFF** barcode below based on your keyboard.



Caps Lock OFF, Non-Japanese Keyboard

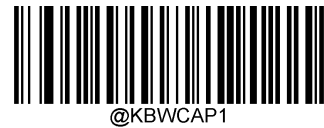

Caps Lock ON, Non-Japanese Keyboard



Emulate ALT+Keypad ON/ Convert All to Upper Case/ Convert All to Lower Case prevails over **Caps Lock ON**.



When the **Caps Lock ON** feature is selected, barcode data "AbC" is transmitted as "aBc".

Convert Case

Scan the appropriate barcode below to convert all bar code data to your desired case.



@KBWCAS0

No Case Conversion



@KBWCAS1

Convert All to Upper Case



@KBWCAS2

Convert All to Lower Case



When the **Convert All to Lower Case** feature is enabled, barcode data “AbC” is transmitted as “abc”.



If **Emulate ALT+Keypad ON** is selected, **Convert All to Lower Case** and **Convert All to Upper Case** do not function.

Emulate Numeric Keypad



Do Not Emulate Numeric Keypad 1: Sending a number (0-9) is emulated as keystroke(s) on main keyboard.

Emulate Numeric Keypad 1: Sending a number (0-9) is emulated as keystroke(s) on numeric keypad. The state of Num Lock on the simulated numeric keypad is determined by its equivalent on the host device. If Num Lock on the host device is turned off, the output of simulated numeric keypad is function key instead of number.

Do Not Emulate Numeric Keypad 2: Sending "+", "-", "*", and "/" is emulated as keystroke(s) on main keyboard.

Emulate Numeric Keypad 2: Sending "+", "-", "*", and "/" is emulated as keystroke(s) on numeric keypad.



@KBWNUM0

Do Not Emulate Numeric Keypad 1

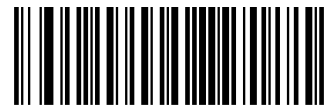

@KBWNUM1

Emulate Numeric Keypad 1



@KBWNCH0

Do Not Emulate Numeric Keypad 2



@KBWNCH1

Emulate Numeric Keypad 2



Emulate ALT+Keypad ON prevails over **Emulate Numeric Keypad**.



Supposing the **Emulate Numeric Keypad 1** feature is enabled:

if Num Lock on the host device is ON, "A4.5" is transmitted as "A4.5";

if Num Lock on the host device is OFF, "A4.5" is transmitted as ".A":

1. "A" is sent on main keyboard;
2. "4" is sent as the function key "Cursor Move to Left";
3. "." is sent on main keyboard;
4. "5" is not sent as it does not correspond to any function key.

Fast Mode

When **Fast Mode On** is selected, the scanner sends characters to the Host faster. If the Host drops characters, turn the Fast Mode off or change the polling rate to a bigger value.



@KBWFAS0

Fast Mode Off



@KBWFAS1

Fast Mode On

Polling Rate

This parameter specifies the polling rate for a USB keyboard. If the Host drops characters, change the polling rate to a bigger value.



USB CDC

If your scanner is connected to the USB port on a host device, the USB CDC feature allows the host device to receive data in the way as a serial port does. A driver is needed when using this feature. You may download it from our website at www.newlandaidc.com.

To ensure stable data transfer, please use host device with USB 3.0 interfaces when transmitting USB data



HID POS (POS HID Barcode Scanner)

Introduction

The HID-POS interface is recommended for new application programs. It can send up to 56 characters in a single USB report and appears more efficient than keyboard emulation.

Features:

- ✧ HID based, no custom driver required.
- ✧ Way more efficient in communication than keyboard emulation and traditional TTL-232 interface.



Access the Scanner with Your Program

Use CreateFile to access the scanner as a HID device and then use ReadFile to deliver the scanned data to the application program. Use WriteFile to send data to the scanner.

For detailed information about USB and HID interfaces, go to www.USB.org.

Acquire Scanned Data

After a barcode is decoded, the scanner sends an input report as below:

| | Bit | | | | | | | |
|-------|---|---|---|---|---|---|---|------------------------|
| Byte | 7 | 6 | 5 | 4 | 3 | 2 | 1 | 0 |
| 0 | Report ID = 0x02 | | | | | | | |
| 1 | Barcode Length | | | | | | | |
| 2-57 | Decoded Data (1-56) | | | | | | | |
| 58-61 | Reserved | | | | | | | |
| 62 | Newland Symbology Identifier or N/C: 0x00 | | | | | | | |
| 63 | - | - | - | - | - | - | - | Decoded data continued |

Send Command to the Scanner

This output report is used to send commands to the scanner. All programming commands can be used.

| | Bit | | | | | | | |
|------|-------------------|---|---|---|---|---|---|---|
| Byte | 7 | 6 | 5 | 4 | 3 | 2 | 1 | 0 |
| 0 | Report ID = 0x04 | | | | | | | |
| 1 | Length of command | | | | | | | |
| 2-63 | Command (1-62) | | | | | | | |

VID/PID

USB uses VID (Vendor ID) and PID (Product ID) to identify and locate a device. The VID is assigned by USB Implementers Forum. Newland's vendor ID is 1EAB (Hex). A range of PIDs are used for each Newland product family. Every PID contains a base number and interface type (keyboard, COM port, etc.).

| Product | Interface | PID (Hex) |
|---------|------------------|-----------|
| FM600 | USB HID Keyboard | 0x4922 |
| | USB CDC | 0x4906 |
| | HID POS | 0x4910 |

Ethernet

When the scanner is connected to the host device using a network cable, communication can be conducted via Ethernet. After setting the scanner to Ethernet communication mode, the “NET” LED will indicate the network connection status. For details, please refer to Chapter Three “LED Indicators”.



Set Ethernet Communication

Ethernet IP Settings:

The default configuration of the Ethernet IP is:

IP: 192.168.1.100

Subnet mask: 255.255.255.0

Gateway 192.168.1.1

Ensure that the scanner and host device are on the same network. You can either set a static IP address or enable DHCP (to automatically obtain an IP).

Device IP configuration

First, ensure that the communication interface is set to Ethernet.

Then, in the Nset main interface, click the device that requires an IP configuration, and select “Network Setup” on the right side. A network configuration window will pop up, where you can choose between a static IP or DHCP (automatically obtain an IP address), as shown in the figure below:

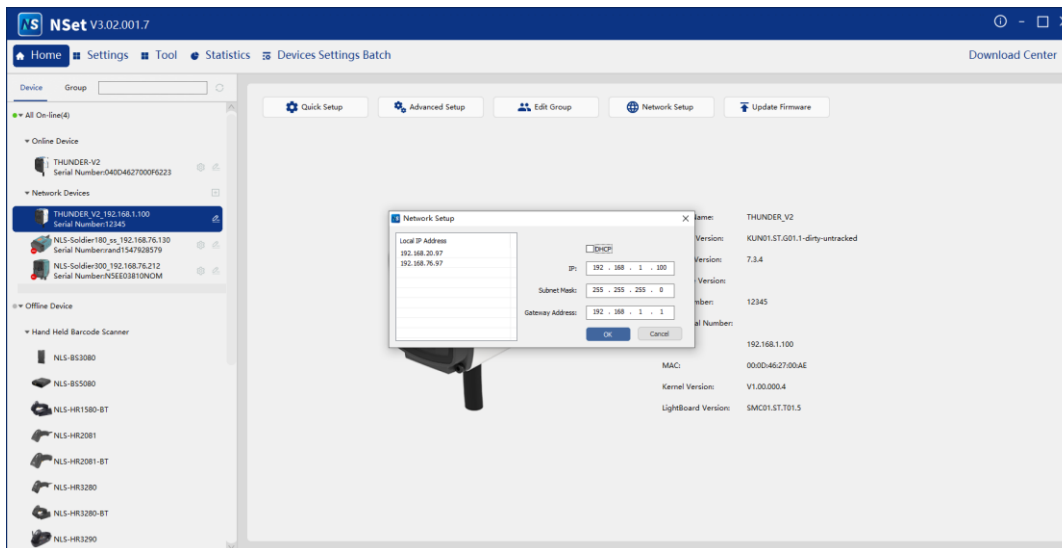

Select DHCP, and then click OK to obtain an IP address via DHCP mode. If DHCP is not selected, a static IP will be used. In this case, configure the IP address, subnet mask, and gateway address as shown in the figure above, and then click OK.



Device Group

Synchronization Mode

In this mode, only the master device within the network can initiate and terminate the scanning process. Slave devices do not have this capability. When the master device is triggered via a button command, it will start decoding and automatically activate all slave devices in the network to begin decoding simultaneously. If a slave device is triggered individually, it will not activate the network-wide decoding process.

Other Parameters of Synchronization Mode

After the slave device decodes, it will be sent to the master device immediately. The master device summarizes all the barcodes, as long as the number of networking barcodes meets the "Maximum Barcode Value", or reaches the "Network Timeout" and the number of networking barcodes is greater than or equal to the "Minimum Barcode Value", the barcode will be outputted, otherwise "NG" will be outputted.

Decoding Mode in Synchronization Mode

The network's decoding mode can only be set to either "Level Mode" or "Pulse Mode". The master device configures the modes based on the actual needs. When "Pulse Mode" is required for the network, the master device is set to "Pulse Mode", while the slave devices are set to "Level Mode" to ensure proper synchronization.

Direct Transmission Mode

The master device directly outputs the barcode of the slave device without any restrictions.

Configure the "Maximum Barcode Value" and "Minimum Barcode Value" for the master and slave device. As shown in the figure below:

1. Edit group

2. Create new group
3. Select master device
4. Set Master-Slave grouping parameters
5. Confirm Master-Slave grouping parameters
6. Confirm grouping configuration

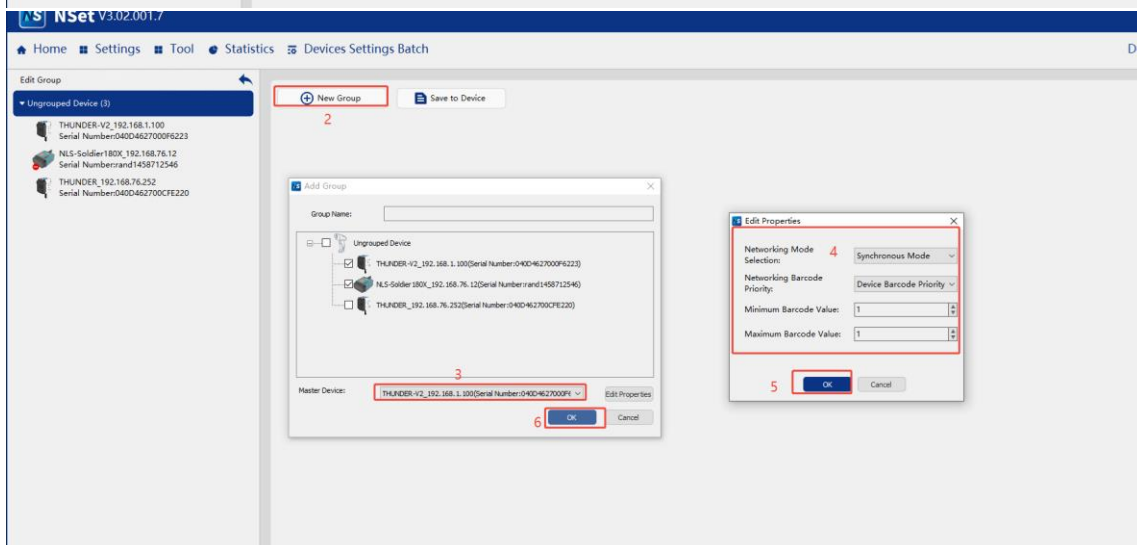
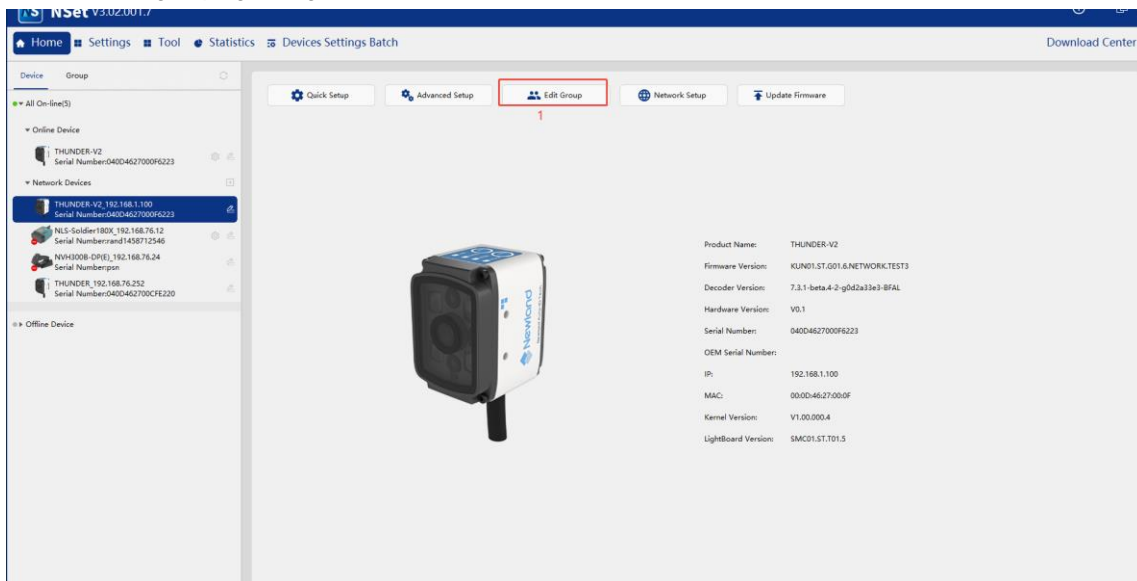

Barcode output channel

TCP Server: Enables the TCP server function to transmit barcode data to remote TCP clients.

TCP Client: Outputs barcode data to a remote TCP Server via a TCP Client.



****Disable TCP Server Output**



Enable TCP Server Output



Disable TCP Client Output



Enable TCP Client Output

Chapter 9 System Settings

Debug Mode

Hold down TUNE to enter debugging mode, where the decoding success rate can be calculated over a certain period.

During decoding, the output format is as follows:

```
"100_81262315067120845800;81262315252974733883;81262315252975452142;81262315252974015543;81262315245595966025;81262315252974493881;81262315148629694587;81262315122355288335;81262315252975210930;81262315245595727537"
```

Here, 100 indicates a decoding success rate of 100%.

Scan Mode

Level Mode: A trigger pull activates a decode session. The decode session continues until a barcode is decoded or you release the trigger.

Sense Mode: The scanner waits for the image stabilization timeout to expire before activating a decode session everytime it detects a change in ambient illumination. Decode session continues until a barcode is decoded or the decode session timeout expires. In this mode, a trigger pull can also activate a decode session. The decode session continues until a barcode is decoded or the trigger is released. When the session ends, the scanner continues to monitor ambient illumination. Timeout between Decodes (Same Barcode) can avoid undesired rereading of same barcode in a given period of time.

Sensitivity can change the Sense Mode's sensibility to changes in ambient illumination.

Continuous Mode: The scanner automatically starts one decode session after another. To suspend/resume barcode reading, simply press the trigger. **Reread Timeout** can avoid undesired rereading of same barcode in a given period of time.

Advanced Sense Mode: The scanner activates a decode session every time it detects a barcode presented to it. The decode session will continue after a barcode is decoded. If the undecoded duration reaches decode session timeout, the scanner will enter the sensor mode. When the scanner detects a barcode presented to it, it will start the decode session again. If rereading of same barcode is required, remove the barcode and then show the barcode on the scan window again.

Trigger Hold Multiple: The scanner enters the barcode reading mode when the trigger is held down. It continuously scans and decodes barcodes until the trigger is released or the "One Reading Timeout" duration is reached. The "Reread Delay" can prevent the same barcode from being read multiple times.

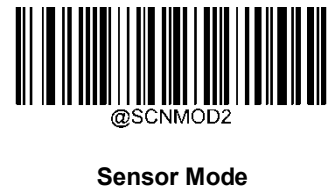

Decode Session Timeout

This parameter sets the maximum time decode session continues during a scan attempt. It is programmable in 1ms increments from 1ms to 3,600,000ms. When it is set to 0, the timeout is infinite. This feature is only applicable to the Pulse, Sense and Level modes.



Decode Session Timeout



Set the decode session timeout to 1,500ms:

1. Scan the **Enter Setup** barcode.
2. Scan the **Decode Session Timeout** barcode.
3. Scan the numeric barcodes "1-", "5", "0" and "0" from the "Digit Barcodes" section in Appendix.
4. Scan the **Save** barcode from the "Save/Cancel Barcodes" section in Appendix.
5. Scan the **Exit Setup** barcode.

Enter the Detection/ Reading State (Sense Mode)

Scan appropriate barcodes below to enable the scanner to enter the detection state or reading state after a good read. This feature is only applicable to the Sense mode.

Enter the Detection State: The scanner stops reading after a barcode is decoded or the decode session timeout expires, and then it starts reading the new barcode presented to it after the Image stabilization timeout expires.

Enter the Reading State: The scanner continues reading after a barcode is decoded or the decode session timeout expires.



Enter the Detection State



Enter the Reading State

Image Stabilization Timeout (Sense Mode)

This parameter defines the amount of time the scanner will spend adapting to ambient environment after it decodes a barcode and “looks” for another. It is programmable in 1ms increments from 0ms to 3,000ms.



Image Stabilization Timeout



Set the image stabilization timeout to 800ms:

1. Scan the **Enter Setup** barcode.
2. Scan the **Image Stabilization Timeout** barcode.
3. Scan the numeric barcodes “8”, “0” and “0” from the “Digit Barcodes” section in Appendix.
4. Scan the **Save** barcode from the “Save/Cancel Barcodes” section in Appendix.
5. Scan the **Exit Setup** barcode.

Trigger Selection (Sense Mode)



@SENTRG0

Image Change Trigger

Image Change Trigger Sensitivity

This specifies the degree of acuteness of the scanner's response to changes in images captured. There are 20 levels to choose from. The smaller the value, the higher the sensitivity and the lower requirement in image change to trigger the scanner. You can select an appropriate degree of sensitivity that fits your application environment. This feature is only applicable to the Sense mode.



@SENLVL14
Low Sensitivity



@SENLVL11
Medium Sensitivity



@SENLVL8
High Sensitivity



@SENLVL5
Enhanced Sensitivity



@SENLVL
Custom Sensitivity (Level 1-20)

E
xample

Set the image change trigger sensitivity to Level 10:

1. Scan the **Enter Setup** barcode.
 2. Scan the **Custom Sensitivity** barcode.
 3. Scan the numeric barcodes "1" and "0" from the "Digit Barcodes" section in Appendix.
 4. Scan the **Save** barcode from the "Save/Cancel Barcodes" section in Appendix.
 5. Scan the **Exit Setup** barcode.
-

Reread Timeout

Reread Timeout can avoid undesired rereading of same barcode in a given period of time. This feature is only applicable to the Sense and Continuous modes.

To enable/disable the Reread Timeout, scan the appropriate barcode below.

Enable Reread Timeout: Do not allow the scanner to re-read same barcode before the reread timeout expires.

Disable Reread Timeout: Allow the scanner to re-read same barcode.



Enable Reread Timeout



Disable Reread Timeout

The following parameter sets the time interval between two successive reads on same barcode. It is programmable in 1ms increments from 0ms to 3,600,000ms. When it is set to a value greater than 3,000, the timeout for rereading same programming barcode is limited to 3,000ms.



Reread Timeout



Set the reread timeout to 1,000ms:

1. Scan the **Enter Setup** barcode.
2. Scan the **Reread Timeout** barcode.
3. Scan the numeric barcodes "1", "0", "0" and "0" from the "Digit Barcodes" section in Appendix.
4. Scan the **Save** barcode from the "Save/Cancel Barcodes" section in Appendix.
5. Scan the **Exit Setup** barcode.

You may wish to restart the reread timeout when the scanner encounters the same barcode that was decoded in the last scan session before the reread timeout expires. To enable this feature, scan the **Reread Timeout Reset On** barcode. This feature is only effective when **Reread Timeout** is enabled.



@RRDREN1

Reread Timeout Reset On



@RRDRENO

Reread Timeout Reset Off

Good Read Delay

Good Read Delay sets the minimum amount of time before the scanner can read another barcode after a good read. This parameter is programmable in 1ms increments from 1ms to 3,600,000ms. Scan the appropriate barcode below to enable or disable the delay.



@GRDNA1

Enable Good Read Delay



@GRDNA0

Disable Good Read Delay

To set the good read delay, scan the barcode below, then set the delay (from 1 to 3,600,000ms) by scanning the digit barcode(s) then scanning the **Save** barcode from the Appendix.



@GRDDUR

Good Read Delay



Set the good read delay to 1,000ms:

1. Scan the **Enter Setup** barcode.
2. Scan the **Good Read Delay** barcode.
3. Scan the numeric barcodes “1”, “0”, “0” and “0” from the “Digit Barcodes” section in Appendix.
4. Scan the **Save** barcode from the “Save/Cancel Barcodes” section in Appendix.
5. Scan the **Exit Setup** barcode.

Security Level

This parameter sets decoding times that is required to correctly read the barcode. The higher the security level, the lower the decoding error rate, but the slower the speed.



@SAFLVL0

Security Level 1



@SAFLVL1

Security Level 2



@SAFLVL2

Security Level 3



@SAFLVL3

Security Level 4

Decode Area

Whole Area Decoding: The scanner attempts to decode barcode(s) within its field of view, from the center to the periphery, and transmits the barcode that has been first decoded.

Multiple Area Decoding: After enabling multiple area decoding, user can specify several areas on the image. The scanner will only decode barcodes within these specified areas.



Whole Area Decoding



Multiple Area Decoding



Users can obtain images through NSet and then directly set multiple decoding areas on the image using `[ROI]`. Alternatively, multiple areas can be set via commands. The command format is as follows:

```
CADMRIxxxSyyylsssLwwwTnnnRmmmB...yyylsssLwwwTnnnRmmmB
```

Where CADMRI is the command name, S indicates the number of decoding areas, with support for up to 64 areas. I represents the index number of the decoding area, L denotes the horizontal coordinate of the top-left corner, T denotes the vertical coordinate of the top-left corner, R denotes the horizontal coordinate of the bottom-right corner, and B denotes the vertical coordinate of the bottom-right corner.

Multi-barcodes Settings

The FM600 device features a multi-barcode parameter setting function, allowing users to configure decoding constraints and define output sequences for multiple barcodes.

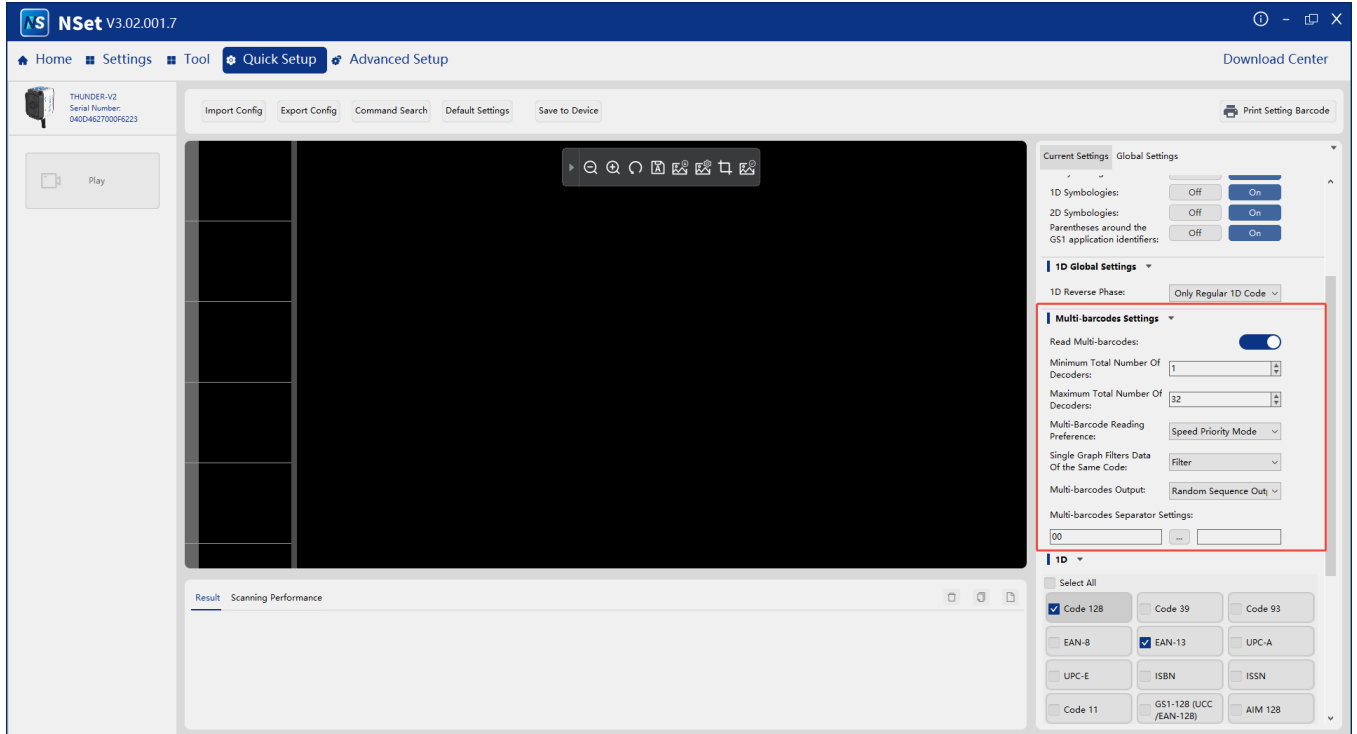

Minimum & Maximum Total Number of Decoders

The number of decoded outputs is randomly determined within the specified range, from the minimum to the maximum limit. The lower limit is defined by the minimum setup value. For example, if the minimum setup is 2 and the maximum setup is 6, a single decoding operation can output 2-6 random barcodes, with a guaranteed minimum of 2. If the total number of decodable barcodes is less than 2, the output will be NG.

Multi-Barcode Reading Preference

Two modes are available: **Speed Priority** and **Quantity Priority**.

- **Quantity Priority**

1. During the trigger time, if the number of decoded barcodes reaches the maximum output limit, the reading process stops in non-continuous modes (Standard, Burst).
2. If the trigger ends and the number of decoded barcodes meets the minimum output limit, the data is output; otherwise, "NG" is output.

- **Speed Priority**

1. During the trigger time, if the number of decoded barcodes meets the minimum output limit, the reading process stops in non-continuous modes (Standard, Burst).
2. If the trigger ends and the number of decoded barcodes meets the minimum output limit, the data is output; otherwise, "NG" is output. In continuous mode, if the minimum output requirement is never met throughout the entire trigger duration, "NG" is output.

- **Examples**

Scenario 1: A product has 5 barcodes, but only 1 is required by the customer. The goal is to read as many barcodes as possible while ensuring a smooth reading experience.

Configuration: Speed Priority, Minimum Decoding Value = 1, Maximum Decoding Value = 5

Scenario 2: The number of barcodes on the product varies; some have 2 barcodes, while others have 3. All barcodes present on the item need to be read.

Configuration: Quantity Priority, Minimum Decoding Value = 2, Maximum Decoding Value = 3

Scenario 3: A product has 5 barcodes, and all must be decoded.

Configuration: Quantity Priority / Speed Priority, Minimum Decoding Value = 5, Maximum Decoding Value = 5

Single Graph Filters Data of The Same code

Filter data for the same barcode in the same image.

Multi-barcodes Position

The positional information of multiple barcodes can be obtained through a command.

Example:

Send:

```
~<SOH>0000@IMG TGT5T0R0F;<ETX>
```

Response:

```
<STX><SOH>0000@IMG TGT5T0R0F2N50C80X80D20A90Q6403M33S24P20L30313233343536373839G0W0H|  
240W270H|309W395H|446W395H50C80S80D20A90Q6403M33S24P20L31323334353637383930G320W272H|45  
1W270H|309W395H|446W395H00058200xxxxxxxxxxxx<ACK>;<ETX>
```

Response Parsing:

The response indicates that two barcodes were decoded.

➤ First barcode details:

Contrast: 50

Signal-to-noise ratio: 80

Clarity: 80

Damage level: 20

Quality: 90

Decoding time: 6403 μ s

Type: QR

PPM: 24

Length: 20

Content: 0123456789 (converted from HEX to string)

Position in image (four coordinates): 0W0H|240W270H|309W395H|446W395H

➤ Second barcode details:

Contrast: 50

Signal-to-noise ratio: 80

Clarity: 80

Damage level: 20

Quality: 90

Decoding time: 6403 μs

Type: QR

PPM: 24

Length: 20

Content: 1234567890 (converted from HEX to string)

Position in image (four coordinates): 320W272H|451W270H|309W395H|446W395H

The remaining data represents the image content. The image length is 0x00058200, and xxxxxxxxxxxx denotes the image data.

Multi-barcodes Output

Random Sequence Output

Output barcode information in random order.

Fixed Sequence Output Mode

Customize the sorting and output barcode information according to the characteristics of symbology type, vertical direction, horizontal direction, etc., and adjust the output priority by moving up/down.

Multi-barcodes Output:

Fixed Sequence Output Mode 2

| | |
|------------|-------------------------------------|
| Vertical | <input type="button" value="Up"/> |
| Horizontal | |
| Barcode | <input type="button" value="Down"/> |

Vertical Direction:

Horizontal Direction:

Click “=> / <=” To add/remove symbology types and adjust output priority by moving up/down.

Barcode

| | | |
|----------------------|--|--|
| Code 128 | <input type="button" value="=>"/> <input type="button" value="<="/> <input type="button" value="Up"/> <input type="button" value="Down"/> <input type="button" value="Clear"/> | |
| GS1-128(UCC/EAN-128) | | |
| EAN-8 | | |
| EAN-13 | | |
| UPC-E | | |
| UPC-A | | |
| Interleaved 2/5 | | |
| ITF-14 | | |
| ITF-6 | | |
| Matrix 2/5 | | |
| Code 39 | | |
| Codabar | | |
| Code 93 | | |
| AIM 128 | | |
| ISBT 128 | | |

Multi-barcodes Separator Settings

Customize the separator between multiple barcodes.

Image Flipping



@MIRROR0

Do Not Flip



@MIRROR2

Flip Vertically



@MIRROR1

Flip Horizontally



@MIRROR3

Flip Horizontally & Vertically

Example of image not flipped



Example of image flipped horizontally



Example of image flipped vertically



Example of image flipped horizontally & vertically



Bad Read Message

Scan the appropriate barcode below to select whether or not to send a bad read message (user-programmable) when a good read does not occur before trigger release, or the decode session timeout expires, or the scanner receives the **Stop Scanning** command (For more information, see the “Serial Trigger Command” section in this Chapter).



@NGRENA0

Bad Read Message OFF



@NGRENA1

Bad Read Message ON

Set Bad Read Message

A bad read message can contain up to 7 characters (HEX values from 0x00 to 0xFF). To set a bad read message, scan the **Set Bad Read Message** barcode, the numeric barcodes representing the hexadecimal values of desired character(s) and the **Save** barcode.



@NGRSET

Set Bad Read Message



Set the bad read message to “F” (HEX: 0x46):

1. Scan the **Enter Setup** barcode.
 2. Scan the **Set Bad Read Message** barcode.
 3. Scan the numeric barcodes “4”, “2”, “4”, “1”, “4” and “4” from the “Digit Barcodes” section in Appendix.
 4. Scan the **Save** barcode from the “Save/Cancel Barcodes” section in Appendix.
 5. Scan the **Exit Setup** barcode.
-

Good Read Signal

The SCAN_OK signal can be used to indicate a good read.

On: The SCAN_OK pin can be used to generate a good read indicator when a good read occurs.

Off: The SCAN_OK pin is unable to generate a good read indicator when a good read occurs.



Polarity of Good Read Signal

Low Level: The SCAN_OK pin produces low level output when a good read occurs.

High Level: The SCAN_OK pin produces high level output when a good read occurs.

Note: You must restart the scanner before this setting will take effect.



Good Read Indicator Duration

This parameter sets the amount of time that the Good Read Indicator to remain on following a good read. It is programmable in 1ms increments from 1ms to 10000ms.



Good Read Indicator Duration



Set the Good Read Indicator duration to 1500ms:

1. Scan the **Enter Setup** barcode.
2. Scan the **Good Read Indicator Duration** barcode.
3. Scan the numeric barcodes "1", "5", "0" and "0" from the "Digit Barcodes" section in Appendix.
4. Scan the **Save** barcode from the "Save/Cancel Barcodes" section in Appendix.
5. Scan the **Exit Setup** barcode.

Good Read Indicator Delay

This parameter sets the delay time for generating a good read indicator when a good read occurs. It is programmable in 1ms increments from 0ms to 10000ms.



Good Read Indicator Delay



Set the Good Read Indicator delay to 1500ms:

1. Scan the **Enter Setup** barcode.
2. Scan the **Good Read Indicator delay** barcode.
3. Scan the numeric barcodes "1", "5", "0" and "0" from the "Digit Barcodes" section in Appendix.
4. Scan the **Save** barcode from the "Save/Cancel Barcodes" section in Appendix.
5. Scan the **Exit Setup** barcode.

Bad Read Signal

The SCAN_NG signal can be used to indicate a bad read.

On: The SCAN_NG pin can be used to generate a bad read indicator when a bad read occurs.

Off: The SCAN_NG pin is unable to generate a bad read indicator when a bad read occurs.



Polarity of Bad Read Signal

Low Level: The SCAN_NG pin produces low level output when a bad read occurs.

High Level: The SCAN_NG pin produces high level output when a bad read occurs.

Note: You must restart the scanner before this setting will take effect.



Bad Read Indicator Duration

This parameter sets the amount of time that the Bad Read Indicator to remain on following a bad read. It is programmable in 1ms increments from 1ms to 10000ms.



Bad Read Indicator Duration



Set the Good Read Indicator duration to 1500ms:

6. Scan the **Enter Setup** barcode.
7. Scan the **Bad Read Indicator Duration** barcode.
8. Scan the numeric barcodes "1", "5", "0" and "0" from the "Digit Barcodes" section in Appendix.
9. Scan the **Save** barcode from the "Save/Cancel Barcodes" section in Appendix.
10. Scan the **Exit Setup** barcode.

Bad Read Indicator Delay

This parameter sets the delay time for generating a bad read indicator when a bad read occurs. It is programmable in 1ms increments from 0ms to 10000ms.



Bad Read Indicator Delay



Set the Bad Read Indicator delay to 1500ms:

6. Scan the **Enter Setup** barcode.
7. Scan the **Bad Read Indicator delay** barcode.
8. Scan the numeric barcodes "1", "5", "0" and "0" from the "Digit Barcodes" section in Appendix.
9. Scan the **Save** barcode from the "Save/Cancel Barcodes" section in Appendix.
10. Scan the **Exit Setup** barcode.

Trigger

Enable or disable the TRIG_IN signal.

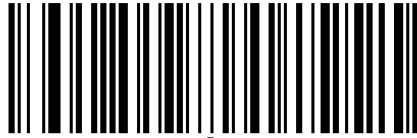

@TRGENA0
Enable Triggering

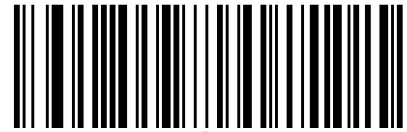

@TRGENA1
Disable Triggering

Trigger Signal

Types of Triggering



@TRGSGN0
Low Level Triggering



@TRGSGN1
High Level Triggering

Debounce

Enable or disable the debounce.



@TBDENA0

Enable Debounce

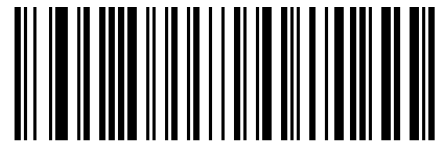

@TBDENA1

Disable Debounce

Debounce Time

Set the debounce time for the TRIG_IN signal.



@TBDDUR

Debounce Time



Set the debounce time to 20ms:

1. Scan the Enter Setup barcode.
2. Scan the **Debounce Time** barcode.
3. Scan the numeric barcodes “2” and “0” from the “Digit Barcodes” section in Appendix.
4. Scan the **Save** barcode from the “Save/Cancel Barcodes” section in Appendix.
5. Scan the **Exit Setup** barcode.

Image Decoding Timeout

Image Decoding Timeout specifies the maximum time the scanner will spend decoding an image.



Image Decoding Timeout

E *xample*

Set the image decoding timeout to 350ms:

1. Scan the **Enter Setup** barcode.
2. Scan the **Image Decoding Timeout** barcode.
3. Scan the numeric barcodes "3", "5", and "0" from the "Digit Barcodes" section in Appendix.
4. Scan the **Save** barcode from the "Save/Cancel Barcodes" section in Appendix.
5. Scan the **Exit Setup** barcode.

Trigger Commands

When **Enable Trigger Commands** is selected, you can activate and deactivate the scanner in the Level mode with serial trigger commands. Sending the **Start Scanning** command (default: **<SOH> T <EOT>**, user-programmable) to the scanner in the Level mode activates a decode session. The decode session continues until a barcode is decoded or the decode session timeout expires or the scanner receives the **Stop Scanning** command (default: **<SOH> P <EOT>**, user-programmable).



Disable Trigger Commands



Enable Trigger Commands

Modify Start Scanning Command

The **Start Scanning** command can consist of 1-10 characters (HEX values from 0x01 to 0xFF). In this command, the character “?” (HEX: 0x3F) cannot be the first character. The default **Start Scanning** command is **<SOH> T <EOT>**.



Modify Start Scanning Command



Set the Start Scanning command to “*T”:

1. Scan the **Enter Setup** barcode.
 2. Scan the **Modify Start Scanning Command** barcode.
 3. Scan the numeric barcodes “0”, “1”, “5”, “3”, “0” and “4” from the “Digit Barcodes” section in Appendix.
 4. Scan the **Save** barcode from the “Save/Cancel Barcodes” section in Appendix.
 5. Scan the **Exit Setup** barcode.
-

Modify Stop Scanning Command

The **Stop Scanning** command can consist of 1-10 characters (HEX values from 0x01 to 0xFF). In this command, the character “?” (HEX: 0x3F) cannot be the first character. The default **Stop Scanning** command is **<SOH> P <EOT>**.



Modify Stop Scanning Command



Set the **Stop Scanning** command to “*P”:

1. Scan the **Enter Setup** barcode.
2. Scan the **Modify Stop Scanning Command** barcode.
3. Scan the numeric barcodes “0”, “1”, “4”, “5”, “0” and “4” from the “Digit Barcodes” section in Appendix.
4. Scan the **Save** barcode from the “Save/Cancel Barcodes” section in Appendix.
5. Scan the **Exit Setup** barcode.

Illumination

Illumination Setting

A couple of illumination options are provided to improve the lighting conditions during every image capture:

Normal: Illumination LEDs are turned on during image capture.

Off: Illumination LEDs are off all the time.



@ILLSCN1

Normal



@ILLSCN0

Off

Lighting Selection

The FM600 provides 4 high-brightness LED lights, choose lighting lights in different positions to meet different scanning needs.



@ILLPST0

Top Light



@ILLPST1

Bottom Light



@ILLPST2

Top Light + Bottom Light



@ILLPST3

Left Light

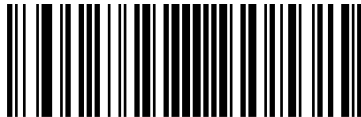

@ILLPST4

Top Light + Left Light



@ILLPST5

Bottom Light + Left Light



@ILLPST6

Top Light + Bottom Light + Left Light



@ILLPST7

Right Light



@ILLPST8

Top Light + Right Light



@ILLPST9

Bottom Light + Right Light

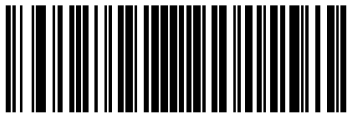

@ILLPST10

Top Light + Bottom Light + Right Light

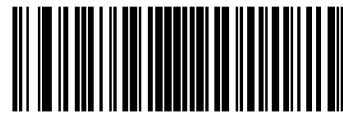

@ILLPST11

Left Light + Right Light

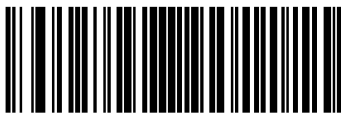

@ILLPST12

Top Light + Left Light + Right Light

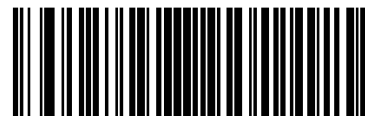

@ILLPST13

Bottom Light + Left Light + Right Light



@ILLPST14

**Top Light + Bottom Light + Left Light +
Right Light**

Aiming

When scanning/capturing image, the engine projects an aiming pattern which allows positioning the target barcode within its field of view and thus makes decoding easier.

Normal: The engine projects an aiming pattern only during barcode scanning/capture.

Always On: Aiming pattern is constantly on after the engine is powered on.

Off: Aiming pattern is off all the time.



Good Read LED

The green LED can be programmed to be On or Off to indicate good read.



@GRLENA1

On



@GRLENA0

Off

Good Read LED Duration

This parameter sets the amount of time that the Good Read LED to remain on following a good read. It is programmable in 1ms increments from 1ms to 2,500ms.



@GRLDUR20

Short (20ms)



@GRLDUR120

Medium (120ms)



@GRLDUR220

Long (220ms)



@GRLDUR320

Prolonged (320ms)



@GRLDUR

Custom (1 - 2,500ms)



Set the Good Read LED duration to 800ms:

1. Scan the **Enter Setup** barcode.
2. Scan the **Custom** barcode.
3. Scan the numeric barcodes “8”, “0” and “0” from the “Digit Barcodes” section in Appendix.
4. Scan the **Save** barcode from the “Save/Cancel Barcodes” section in Appendix.
5. Scan the **Exit Setup** barcode.

Power On Beep

The scanner can be programmed to beep when it is powered on. Scan the **Off** barcode if you do not want a power on beep.



@PWBENA1

On



@PWBENA0

Off

Good Read Beep

Scanning the **Off** barcode can turn off the beep that indicates successful decode; scanning the **On** barcode can turn it back on.



@GRBENA1

On



@GRBENA0

Off

Good Read Beep Volume

There are 20 volume levels to choose from. The bigger the value, the louder the Good Read Beep.



@GRBVLL20

Loud



@GRBVLL12

Medium



@GRBVLL5

Low



@GRBVLL

Custom Volume (Level 1-20)



Set the Good Read Beep volume to Level 10:

1. Scan the **Enter Setup** barcode.
2. Scan the **Custom Volume** barcode.
3. Scan the numeric barcode “1” and “0” from the “Digit Barcodes” section in Appendix.
4. Scan the **Save** barcode from the “Save/Cancel Barcodes” section in Appendix.
5. Scan the **Exit Setup** barcode.

Good Read Beep Duration

This parameter sets the length of the beep the scanner emits on a good read. It is programmable in 1ms increments from 20ms to 300ms.



@GRBDUR40

Short (40ms)



@GRBDUR80

Medium (80ms)



@GRBDUR120

Long (120ms)



@GRBDUR

Custom (20 – 300ms)



Set the Good Read Beep duration to 200ms:

1. Scan the **Enter Setup** barcode.
2. Scan the **Custom** barcode.
3. Scan the numeric barcodes “2”, “0” and “0” from the “Digit Barcodes” section in Appendix.
4. Scan the **Save** barcode from the “Save/Cancel Barcodes” section in Appendix.
5. Scan the **Exit Setup** barcode.

Good Read Beep Frequency

This parameter is programmable in 1Hz increments from 20Hz to 20,000Hz.



@GRBFRQ800
Extra Low (800Hz)



@GRBFRQ1600
Low (1600Hz)



@GRBFRQ2730
Medium (2730Hz)



@GRBFRQ4200
High (4200Hz)



@GRBFRQ
Custom (20 - 20,000Hz)

Chapter 10 Symbologies

Introduction

Every symbology (barcode type) has its own unique attributes. This chapter provides programming barcodes for configuring the scanner so that it can identify various symbologies. It is recommended to disable those that are rarely used to increase the efficiency of the scanner.

Global Settings

Enable/Disable All Symbologies

Despite the **Enable All Symbologies** feature is enabled, the scanner still cannot read Pharmacode. Pharmacode must be enabled separately. For details, please refer to the Pharmacode settings.

If the **Disable All Symbologies** feature is enabled, the scanner will not be able to read any non-programming barcodes except the programming barcodes.



Enable All Symbologies



Disable All Symbologies

Enable/Disable 1D Symbologies

Despite the **Enable All Symbologies** feature is enabled, the scanner still cannot read Pharmacode. Pharmacode must be enabled separately. For details, please refer to the Pharmacode settings.



Enable 1D Symbologies



Disable 1D Symbologies

Enable/Disable 2D Symbologies



Enable 2D Symbologies



Disable 2D Symbologies

Enable/Disable Postal Symbologies



Enable All Postal Symbologies



Disable All Postal Symbologies

Inverse Code

Regular barcode: Dark bars on a bright background.

Inverse barcode: Bright bars on a dark background.

- ✧ **Regular 1D Code Only:** Read regular 1D code only.
- ✧ **Inverse 1D Code Only:** Read inverse 1D codes only.
- ✧ **Both Regular & Inverse:** Read both regular and inverse 1D codes.



Regular 1D Code Only



Inverse 1D Code Only



Both Regular & Inverse

Surround GS1 Application Identifiers (AI's) with Parentheses

When **Surround GS1 AI's with Parentheses** is selected, each application identifier (AI) contained in scanned data will be enclosed in parentheses in the output message.



Do Not Surround GS1 AI's with Parentheses



Surround GS1 AI's with Parentheses

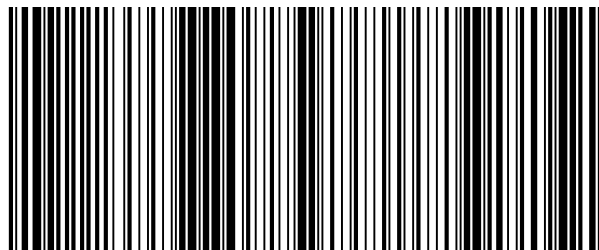

(01) 0 0614141 99999 6 (10) 10ABCEDF123456

If **Surround GS1 AI's with Parentheses** is selected, the barcode above is output as (01)00614141999996(10)10ABCEDF123456.

If **Do Not Surround GS1 AI's with Parentheses** is selected, the barcode above is output as 01006141419999961010ABCEDF123456.

Code 128

Restore Factory Defaults



@128DEF

Restore the Factory Defaults of Code 128

Enable/Disable Code 128



@128ENA1

Enable Code 128



@128ENA0

Disable Code 128



If the scanner fails to identify Code 128 barcodes, you may first try this solution by scanning the **Enter Setup** barcode and then **Enable Code 128** barcode.

Set Length Range for Code 128

The scanner can be configured to only decode Code 128 barcodes with lengths that fall between (inclusive) the minimum and maximum lengths. To accomplish it, you need to set the minimum and maximum lengths.



Set the Minimum Length



Set the Maximum Length



If minimum length is set to be greater than maximum length, the scanner only decodes Code 128 barcodes with either the minimum or maximum length. If minimum length is same as maximum length, only Code 128 barcodes with that length are to be decoded.



Set the scanner to decode Code 128 barcodes containing between 8 and 12 characters:

1. Scan the **Enter Setup** barcode.
2. Scan the **Set the Minimum Length** barcode.
3. Scan the numeric barcode "8" from the "Digit Barcodes" section in Appendix.
4. Scan the **Save** barcode from the "Save/Cancel Barcodes" section in Appendix.
5. Scan the **Set the Maximum Length** barcode.
6. Scan the numeric barcodes "1" and "2" from the "Digit Barcodes" section in Appendix.
7. Scan the **Save** barcode from the "Save/Cancel Barcodes" section in Appendix.
8. Scan the **Exit Setup** barcode.

EAN-8

Restore Factory Defaults



@EA8DEF

Restore the Factory Defaults of EAN-8

Enable/Disable EAN-8



@EA8ENA1

Enable EAN-8



@EA8ENA0

Disable EAN-8



If the scanner fails to identify EAN-8 barcodes, you may first try this solution by scanning the **Enter Setup** barcode and then **Enable EAN-8** barcode.

Transmit Check Character

EAN-8 is 8 digits in length with the last one as its check character used to verify the integrity of the data.



Transmit EAN-8 Check Character



Do Not Transmit EAN-8 Check Character

2-Digit Add-On Code

An EAN-8 barcode can be augmented with a two-digit add-on code to form a new one. In the example below, the part surrounded by blue dotted line is an EAN-8 barcode while the part circled by red dotted line is a two-digit add-on code.



Disable 2-Digit Add-On Code



Enable 2-Digit Add-On Code



Disable 2-Digit Add-On Code: The scanner decodes EAN-8 and ignores the add-on code when presented with an EAN-8 plus 2-digit add-on barcode. It can also decode EAN-8 barcodes without 2-digit add-on codes.

Enable 2-Digit Add-On Code: The scanner decodes a mix of EAN-8 barcodes with and without 2-digit add-on codes.

5-Digit Add-On Code

An EAN-8 barcode can be augmented with a five-digit add-on code to form a new one. In the example below, the part surrounded by blue dotted line is an EAN-8 barcode while the part circled by red dotted line is a five-digit add-on code.



Disable 5-Digit Add-On Code



Enable 5-Digit Add-On Code



Disable 5-Digit Add-On Code: The scanner decodes EAN-8 and ignores the add-on code when presented with an EAN-8 plus 5-digit add-on barcode. It can also decode EAN-8 barcodes without 5-digit add-on codes.

Enable 5-Digit Add-On Code: The scanner decodes a mix of EAN-8 barcodes with and without 5-digit add-on codes.

Add-On Code Required

When **EAN-8 Add-On Code Required** is selected, the scanner will only read EAN-8 barcodes that contain add-on codes.



@EA8REQ0

EAN-8 Add-On Code Not Required



@EA8REQ1

EAN-8 Add-On Code Required

EAN-13

Restore Factory Defaults



Restore the Factory Defaults of EAN-13

Enable/Disable EAN-13



Enable EAN-13



Disable EAN-13



If the scanner fails to identify EAN-13 barcodes, you may first try this solution by scanning the **Enter Setup** barcode and then **Enable EAN-13** barcode.

Transmit Check Character



Transmit EAN-13 Check Character



Do Not Transmit EAN-13 Check Character

2-Digit Add-On Code

An EAN-13 barcode can be augmented with a two-digit add-on code to form a new one. In the example below, the part surrounded by blue dotted line is an EAN-13 barcode while the part circled by red dotted line is a two-digit add-on code.



Disable 2-Digit Add-On Code



Enable 2-Digit Add-On Code



Disable 2-Digit Add-On Code: The scanner decodes EAN-13 and ignores the add-on code when presented with an EAN-13 plus 2-digit add-on barcode. It can also decode EAN-13 barcodes without 2-digit add-on codes.

Enable 2-Digit Add-On Code: The scanner decodes a mix of EAN-13 barcodes with and without 2-digit add-on codes.

5-Digit Add-On Code

An EAN-13 barcode can be augmented with a five-digit add-on code to form a new one. In the example below, the part surrounded by blue dotted line is an EAN-13 barcode while the part circled by red dotted line is a five-digit add-on code.



Disable 5-Digit Add-On Code



Enable 5-Digit Add-On Code



Disable 5-Digit Add-On Code: The scanner decodes EAN-13 and ignores the add-on code when presented with an EAN-13 plus 5-digit add-on barcode. It can also decode EAN-13 barcodes without 5-digit add-on codes.

Enable 5-Digit Add-On Code: The scanner decodes a mix of EAN-13 barcodes with and without 5-digit add-on codes.

Add-On Code Required

When **EAN-13 Add-On Code Required** is selected, the scanner will only read EAN-13 barcodes that contain add-on codes.



EAN-13 Add-On Code Not Required



EAN-13 Add-On Code Required

UPC-E

Restore Factory Defaults



@UPEDEF

Restore the Factory Defaults of UPC-E

Enable/Disable UPC-E



@UPEEN01

Enable UPC-E0



@UPEEN11

Enable UPC-E1



@UPEEN00

Disable UPC-E0



@UPEEN10

Disable UPC-E1



If the scanner fails to identify UPC-E0/UPC-E1 barcodes, you may first try this solution by scanning the **Enter Setup** barcode and then **Enable UPC-E0/UPC-E1** barcode.

Transmit Check Character

UPC-E is 8 digits in length with the last one as its check character used to verify the integrity of the data.



Transmit UPC-E Check Character



Do Not Transmit UPC-E Check Character

2-Digit Add-On Code

A UPC-E barcode can be augmented with a two-digit add-on code to form a new one. In the example below, the part surrounded by blue dotted line is a UPC-E barcode while the part circled by red dotted line is a two-digit add-on code.



Disable 2-Digit Add-On Code



Enable 2-Digit Add-On Code



Disable 2-Digit Add-On Code: The scanner decodes UPC-E and ignores the add-on code when presented with a UPC-E plus 2-digit add-on barcode. It can also decode UPC-E barcodes without 2-digit add-on codes.

Enable 2-Digit Add-On Code: The scanner decodes a mix of UPC-E barcodes with and without 2-digit add-on codes.

5-Digit Add-On Code

A UPC-E barcode can be augmented with a five-digit add-on code to form a new one. In the example below, the part surrounded by blue dotted line is a UPC-E barcode while the part circled by red dotted line is a five-digit add-on code.



Disable 5-Digit Add-On Code



Enable 5-Digit Add-On Code



Disable 5-Digit Add-On Code: The scanner decodes UPC-E and ignores the add-on code when presented with a UPC-E plus 5-digit add-on barcode. It can also decode UPC-E barcodes without 5-digit add-on codes.

Enable 5-Digit Add-On Code: The scanner decodes a mix of UPC-E barcodes with and without 5-digit add-on codes.

Add-On Code Required

When **UPC-E Add-On Code Required** is selected, the scanner will only read UPC-E barcodes that contain add-on codes.



UPC-E Add-On Code Not Required



UPC-E Add-On Code Required

Transmit Preamble Character

Preamble characters (Country Code and System Character) can be transmitted as part of a UPC-E barcode. Select one of the following options for transmitting UPC-E preamble to the host device: transmit system character only, transmit system character and country code ("0" for USA), or transmit no preamble.



@UPEPRE1

System Character



@UPEPRE0

No Preamble

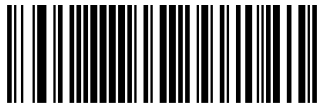

@UPEPRE2

System Character & Country Code

UPC-A

Restore Factory Defaults



Restore the Factory Defaults of UPC-A

Enable/Disable UPC-A



Enable UPC-A



Disable UPC-A



If the scanner fails to identify UPC-A barcodes, you may first try this solution by scanning the **Enter Setup** barcode and then **Enable UPC-A** barcode.

Transmit Check Character

UPC-A is 13 digits in length with the last one as its check character used to verify the integrity of the data.



Transmit UPC-A Check Character



Do Not Transmit UPC-A Check Character

2-Digit Add-On Code

A UPC-A barcode can be augmented with a two-digit add-on code to form a new one. In the example below, the part surrounded by blue dotted line is a UPC-A barcode while the part circled by red dotted line is a two-digit add-on code.



Disable 2-Digit Add-On Code



Enable 2-Digit Add-On Code



Disable 2-Digit Add-On Code: The scanner decodes UPC-A and ignores the add-on code when presented with a UPC-A plus 2-digit add-on barcode. It can also decode UPC-A barcodes without 2-digit add-on codes.

Enable 2-Digit Add-On Code: The scanner decodes a mix of UPC-A barcodes with and without 2-digit add-on codes.

5-Digit Add-On Code

A UPC-A barcode can be augmented with a five-digit add-on code to form a new one. In the example below, the part surrounded by blue dotted line is a UPC-A barcode while the part circled by red dotted line is a five-digit add-on code.



Disable 5-Digit Add-On Code



Enable 5-Digit Add-On Code



Disable 5-Digit Add-On Code: The scanner decodes UPC-A and ignores the add-on code when presented with a UPC-A plus 5-digit add-on barcode. It can also decode UPC-A barcodes without 5-digit add-on codes.

Enable 5-Digit Add-On Code: The scanner decodes a mix of UPC-A barcodes with and without 5-digit add-on codes.

Add-On Code Required

When **UPC-A Add-On Code Required** is selected, the scanner will only read UPC-A barcodes that contain add-on codes.



UPC-A Add-On Code Not Required



UPC-A Add-On Code Required

Transmit Preamble Character

Preamble characters (Country Code and System Character) can be transmitted as part of a UPC-A barcode. Select one of the following options for transmitting UPC-A preamble to the host device: transmit system character only, transmit system character and country code ("0" for USA), or transmit no preamble.



No Preamble



System Character



System Character & Country Code

Coupon

UPC-A/EAN-13 with Extended Coupon Code

The following three types of coupon code + extended coupon code are supported:

- ✧ UPC-A (starting with “5”) + GS1-128
- ✧ UPC-A (starting with “5”) + GS1 Databar
- ✧ EAN-13 (starting with “99”) + GS1-128

Use the appropriate barcode below to enable or disable UPC-A/EAN-13 with Extended Coupon Code. When left on the default setting (**Off**), the scanner treats Coupon Codes and Extended Coupon Codes as single barcodes.

If you scan the **Allow Concatenation** code, when the scanner sees the coupon code and the extended coupon code in a single scan, it transmits both as separate symbologies. Otherwise, it transmits the first coupon code it reads.

If you scan the **Require Concatenation** code, the scanner must see and read the coupon code and extended coupon code in a single read to transmit the data. No data is output unless both codes are read.



@CPNENA0

** Off



@CPNENA1

Allow Concatenation



@CPNENA2

Require Concatenation



When using the UPC-A Coupon feature, please ensure that **System Character** or **System Character & Country Code** is selected for the “Transmit UPC-A Preamble Character” feature.

Coupon GS1 Databar Output

If you scan coupons that have both UPC and GS1 Databar codes, you may wish to scan and output only the data from the GS1 Databar code. Scan the **GS1 Output On barcode** below to scan and output only the GS1 Databar code data.

When **GS1 Output Off** is selected, coupons that have both UPC and GS1 Databar codes are transmitted depending on your selection for the “UPC-A/EAN-13 with Extended Coupon Code” feature.



@CPNGS10

**** GS1 Output Off**



@CPNGS11

GS1 Output On



When using the UPC-A Coupon feature, please ensure that **System Character** or **System Character & Country Code** is selected for the “Transmit UPC-A Preamble Character” feature

Interleaved 2 of 5

Restore Factory Defaults



Restore the Factory Defaults of Interleaved 2 of 5

Enable/Disable Interleaved 2 of 5



Enable Interleaved 2 of 5



Disable Interleaved 2 of 5



If the scanner fails to identify Interleaved 2 of 5 barcodes, you may first try this solution by scanning the **Enter Setup** barcode and then **Enable Interleaved 2 of 5** barcode.

Set Length Range for Interleaved 2 of 5

The scanner can be configured to only decode Interleaved 2 of 5 barcodes with lengths that fall between (inclusive) the minimum and maximum lengths. To accomplish it, you need to set the minimum and maximum lengths.



Set the Minimum Length



Set the Maximum Length



If minimum length is set to be greater than maximum length, the scanner only decodes Interleaved 2 of 5 barcodes with either the minimum or maximum length. If minimum length is same as maximum length, only Interleaved 2 of 5 barcodes with that length are to be decoded.



Set the scanner to decode Interleaved 2 of 5 barcodes containing between 8 and 12 characters:

1. Scan the **Enter Setup** barcode.
 2. Scan the **Set the Minimum Length** barcode.
 3. Scan the numeric barcode "8" from the "Digit Barcodes" section in Appendix.
 4. Scan the **Save** barcode from the "Save/Cancel Barcodes" section in Appendix.
 5. Scan the **Set the Maximum Length** barcode.
 6. Scan the numeric barcodes "1" and "2" from the "Digit Barcodes" section in Appendix.
 7. Scan the **Save** barcode from the "Save/Cancel Barcodes" section in Appendix.
 8. Scan the **Exit Setup** barcode.
-

Check Character Verification

A check character is optional for Interleaved 2 of 5 and can be added as the last character. It is a calculated value used to verify the integrity of the data.

- ✧ **Disable:** The scanner transmits Interleaved 2 of 5 barcodes as is.
- ✧ **Do Not Transmit Check Character After Verification:** The scanner checks the integrity of all Interleaved 2 of 5 barcodes to verify that the data complies with the check character algorithm. Barcodes passing the check will be transmitted except the last digit, whereas those failing it will not be transmitted.
- ✧ **Transmit Check Character After Verification:** The scanner checks the integrity of all Interleaved 2 of 5 barcodes to verify that the data complies with the check character algorithm. Barcodes passing the check will be transmitted, whereas those failing it will not be transmitted.

Since Interleaved 2 of 5 must always have an even number of digits, a zero may need to be added as the first digit when the check character is added. The check character is automatically generated when making Interleaved 2 of 5 barcodes.



Disable



Do Not Transmit Check Character After Verification



Transmit Check Character After Verification



If the **Do Not Transmit Check Character After Verification** option is enabled, Interleaved 2 of 5 barcodes with a length that is less than the configured minimum length after having the check character excluded will not be decoded. (For example, when the **Do Not Transmit Check Character After Verification** option is enabled and the minimum length is set to 4, Interleaved 2 of 5 barcodes with a total length of 4 characters including the check character cannot be read.)

ITF-14

ITF-14 is a special kind of Interleaved 2 of 5 with a length of 14 characters and the last character as the check character.

ITF-14 priority principle: For the Interleaved 2 of 5 barcodes with a length of 14 characters and the last character as the check character, the ITF-14 configurations shall take precedence over the Interleaved 2 of 5 settings.

Restore Factory Defaults



Restore the Factory Defaults of ITF-14

Enable/Disable ITF-14



Disable ITF-14



Enable ITF-14 But Do Not Transmit Check Character



Enable ITF-14 and Transmit Check Character



An example of the ITF-14 priority principle: when ITF-14 is enabled and Interleaved 2 of 5 is disabled, the scanner only decodes Interleaved 2 of 5 barcodes with a length of 14 characters and the last character as the check character.

ITF-6

ITF-6 is a special kind of Interleaved 2 of 5 with a length of 6 characters and the last character as the check character.

ITF-6 priority principle: For the Interleaved 2 of 5 barcodes with a length of 6 characters and the last character as the check character, the ITF-6 configurations shall take precedence over the Interleaved 2 of 5 settings.

Restore Factory Defaults



Restore the Factory Defaults of ITF-6

Enable/Disable ITF-6



Disable ITF-6



Enable ITF-6 But Do Not Transmit Check Character



Enable ITF-6 and Transmit Check Character



An example of the ITF-6 priority principle: when ITF-6 is enabled and Interleaved 2 of 5 is disabled, the scanner only decodes Interleaved 2 of 5 barcodes with a length of 6 characters and the last character as the check character.

Matrix 2 of 5

Restore Factory Defaults



@M25DEF

Restore the Factory Defaults of Matrix 2 of 5

Enable/Disable Matrix 2 of 5



@M25ENA1

Enable Matrix 2 of 5



@M25ENA0

Disable Matrix 2 of 5



If the scanner fails to identify Matrix 2 of 5 barcodes, you may first try this solution by scanning the **Enter Setup** barcode and then **Enable Matrix 2 of 5** barcode.

Set Length Range for Matrix 2 of 5

The scanner can be configured to only decode Matrix 2 of 5 barcodes with lengths that fall between (inclusive) the minimum and maximum lengths. To accomplish it, you need to set the minimum and maximum lengths.



Set the Minimum Length



Set the Maximum Length



If minimum length is set to be greater than maximum length, the scanner only decodes Matrix 2 of 5 barcodes with either the minimum or maximum length. If minimum length is same as maximum length, only Matrix 2 of 5 barcodes with that length are to be decoded.



Set the scanner to decode Matrix 2 of 5 barcodes containing between 8 and 12 characters:

1. Scan the **Enter Setup** barcode.
2. Scan the **Set the Minimum Length** barcode.
3. Scan the numeric barcode "8" from the "Digit Barcodes" section in Appendix.
4. Scan the **Save** barcode from the "Save/Cancel Barcodes" section in Appendix.
5. Scan the **Set the Maximum Length** barcode.
6. Scan the numeric barcodes "1" and "2" from the "Digit Barcodes" section in Appendix.
7. Scan the **Save** barcode from the "Save/Cancel Barcodes" section in Appendix.
8. Scan the **Exit Setup** barcode.

Check Character Verification

A check character is optional for Matrix 2 of 5 and can be added as the last character. It is a calculated value used to verify the integrity of the data.

- ❖ **Disable:** The scanner transmits Matrix 2 of 5 barcodes as is.
- ❖ **Do Not Transmit Check Character After Verification:** The scanner checks the integrity of all Matrix 2 of 5 barcodes to verify that the data complies with the check character algorithm. Barcodes passing the check will be transmitted except the last digit, whereas those failing it will not be transmitted.
- ❖ **Transmit Check Character After Verification:** The scanner checks the integrity of all Matrix 2 of 5 barcodes to verify that the data complies with the check character algorithm. Barcodes passing the check will be transmitted, whereas those failing it will not be transmitted.

Since Matrix 2 of 5 must always have an even number of digits, a zero may need to be added as the first digit when the check character is added. The check character is automatically generated when making Matrix 2 of 5 barcodes.



Disable



Do Not Transmit Check Character After Verification



Transmit Check Character After Verification



If the **Do Not Transmit Check Character After Verification** option is enabled, Matrix 2 of 5 barcodes with a length that is less than the configured minimum length after having the check character excluded will not be decoded. (For example, when the **Do Not Transmit Check Character After Verification** option is enabled and the minimum length is set to 4, Matrix 2 of 5 barcodes with a total length of 4 characters including the check character cannot be read.)

Code 39

Restore Factory Defaults



@C39DEF

Restore the Factory Defaults of Code 39

Enable/Disable Code 39



@C39ENA1

Enable Code 39



@C39ENA0

Disable Code 39



If the scanner fails to identify Code 39 barcodes, you may first try this solution by scanning the **Enter Setup** barcode and then **Enable Code 39** barcode.

Set Length Range for Code 39

The scanner can be configured to only decode Code 39 barcodes with lengths that fall between (inclusive) the minimum and maximum lengths. To accomplish it, you need to set the minimum and maximum lengths.



Set the Minimum Length



Set the Maximum Length



If minimum length is set to be greater than maximum length, the scanner only decodes Code 39 barcodes with either the minimum or maximum length. If minimum length is same as maximum length, only Code 39 barcodes with that length are to be decoded.



Set the scanner to decode Code 39 barcodes containing between 8 and 12 characters:

1. Scan the **Enter Setup** barcode.
2. Scan the **Set the Minimum Length** barcode.
3. Scan the numeric barcode "8" from the "Digit Barcodes" section in Appendix.
4. Scan the **Save** barcode from the "Save/Cancel Barcodes" section in Appendix.
5. Scan the **Set the Maximum Length** barcode.
6. Scan the numeric barcodes "1" and "2" from the "Digit Barcodes" section in Appendix.
7. Scan the **Save** barcode from the "Save/Cancel Barcodes" section in Appendix.
8. Scan the **Exit Setup** barcode.

Check Character Verification

A check character is optional for Code 39 and can be added as the last character. It is a calculated value used to verify the integrity of the data.

- ✧ **Disable:** The scanner transmits Code 39 barcodes as is.
- ✧ **Do Not Transmit Check Character After Verification:** The scanner checks the integrity of all Code 39 barcodes to verify that the data complies with the check character algorithm. Barcodes passing the check will be transmitted except the last digit, whereas those failing it will not be transmitted.
- ✧ **Transmit Check Character After Verification:** The scanner checks the integrity of all Code 39 barcodes to verify that the data complies with the check character algorithm. Barcodes passing the check will be transmitted, whereas those failing it will not be transmitted.



Disable



Do Not Transmit Check Character After Verification



Transmit Check Character After Verification



If the **Do Not Transmit Check Character After Verification** option is enabled, Code 39 barcodes with a length that is less than the configured minimum length after having the check character excluded will not be decoded. (For example, when the **Do Not Transmit Check Character After Verification** option is enabled and the minimum length is set to 4, Code 39 barcodes with a total length of 4 characters including the check character cannot be read.)

Transmit Start/Stop Character

Code 39 uses an asterisk (*) for both the start and the stop characters. You can choose whether or not to transmit the start/stop characters by scanning the appropriate barcode below.



Do Not Transmit Start/Stop Character



Transmit Start/Stop Character

Enable/Disable Code 39 Full ASCII

The scanner can be configured to identify all ASCII characters by scanning the appropriate barcode below.



Disable Code 39 Full ASCII



Enable Code 39 Full ASCII

Enable/Disable Code 32 (Italian Pharma Code)

Code 32 is a variant of Code 39 used by the Italian pharmaceutical industry. Scan the appropriate bar code below to enable or disable Code 32. Code 39 must be enabled and Code 39 check character verification must be disabled for this parameter to function.



@C39E320

Disable Code 32



@C39E321

Enable Code 32

Code 32 Prefix

Scan the appropriate barcode below to enable or disable adding the prefix character "A" to all Code 32 barcodes. Code 32 must be enabled for this parameter to function.



@C39S320

Disable Code 32 Prefix



@C39S321

Enable Code 32 Prefix

Transmit Code 32 Start/Stop Character

Code 32 must be enabled for this parameter to function.



@C39T320

Do Not Transmit Code 32 Start/Stop Character



@C39T321

Transmit Code 32 Start/Stop Character

Transmit Code 32 Check Character

Code 32 must be enabled for this parameter to function.



@C39C320

Do Not Transmit Code 32 Check Character



@C39C321

Transmit Code 32 Check Character

Codabar

Restore Factory Defaults



Restore the Factory Defaults of Codabar

Enable/Disable Codabar



Enable Codabar



Disable Codabar



If the scanner fails to identify Codabar barcodes, you may first try this solution by scanning the **Enter Setup** barcode and then **Enable Codabar** barcode.

Set Length Range for Codabar

The scanner can be configured to only decode Codabar barcodes with lengths that fall between (inclusive) the minimum and maximum lengths. To accomplish it, you need to set the minimum and maximum lengths.



Set the Minimum Length



Set the Maximum Length



If minimum length is set to be greater than maximum length, the scanner only decodes Codabar barcodes with either the minimum or maximum length. If minimum length is same as maximum length, only Codabar barcodes with that length are to be decoded.



Set the scanner to decode Codabar barcodes containing between 8 and 12 characters:

1. Scan the **Enter Setup** barcode.
 2. Scan the **Set the Minimum Length** barcode.
 3. Scan the numeric barcode "8" from the "Digit Barcodes" section in Appendix.
 4. Scan the **Save** barcode from the "Save/Cancel Barcodes" section in Appendix.
 5. Scan the **Set the Maximum Length** barcode.
 6. Scan the numeric barcodes "1" and "2" from the "Digit Barcodes" section in Appendix.
 7. Scan the **Save** barcode from the "Save/Cancel Barcodes" section in Appendix.
 8. Scan the **Exit Setup** barcode.
-

Check Character Verification

A check character is optional for Codabar and can be added as the last character. It is a calculated value used to verify the integrity of the data.

- ✧ **Disable:** The scanner transmits Codabar barcodes as is.
- ✧ **Do Not Transmit Check Character After Verification:** The scanner checks the integrity of all Codabar barcodes to verify that the data complies with the check character algorithm. Barcodes passing the check will be transmitted except the last digit, whereas those failing it will not be transmitted.
- ✧ **Transmit Check Character After Verification:** The scanner checks the integrity of all Codabar barcodes to verify that the data complies with the check character algorithm. Barcodes passing the check will be transmitted, whereas those failing it will not be transmitted.



Disable



Do Not Transmit Check Character After Verification



Transmit Check Character After Verification



If the **Do Not Transmit Check Character After Verification** option is enabled, Codabar barcodes with a length that is less than the configured minimum length after having the check character excluded will not be decoded. (For example, when the **Do Not Transmit Check Character After Verification** option is enabled and the minimum length is set to 4, Codabar barcodes with a total length of 4 characters including the check character cannot be read.)

Start/Stop Character

You can set the start/stop characters and choose whether or not to transmit the start/stop characters by scanning the appropriate barcode below.



@CBATSC0

Do Not Transmit Start/Stop Character



@CBATSC1

Transmit Start/Stop Character



@CBASCF0

ABCD/ABCD as the Start/Stop Character



@CBASCF1

ABCD/TN*E as the Start/Stop Character



@CBASCF2

abcd/abcd as the Start/Stop Character



@CBASCF3

abcd/tn*e as the Start/Stop Character

Code 93

Restore Factory Defaults



@C93DEF

Restore the Factory Defaults of Code 93

Enable/Disable Code 93



@C93ENA1

Enable Code 93



@C93ENA0

Disable Code 93



If the scanner fails to identify Code 93 barcodes, you may first try this solution by scanning the **Enter Setup** barcode and then **Enable Code 93** barcode.

Set Length Range for Code 93

The scanner can be configured to only decode Code 93 barcodes with lengths that fall between (inclusive) the minimum and maximum lengths. To accomplish it, you need to set the minimum and maximum lengths.



Set the Minimum Length



Set the Maximum Length



If minimum length is set to be greater than maximum length, the scanner only decodes Code 93 barcodes with either the minimum or maximum length. If minimum length is same as maximum length, only Code 93 barcodes with that length are to be decoded.



Set the scanner to decode Code 93 barcodes containing between 8 and 12 characters:

1. Scan the **Enter Setup** barcode.
 2. Scan the **Set the Minimum Length** barcode.
 3. Scan the numeric barcode "8" from the "Digit Barcodes" section in Appendix.
 4. Scan the **Save** barcode from the "Save/Cancel Barcodes" section in Appendix.
 5. Scan the **Set the Maximum Length** barcode.
 6. Scan the numeric barcodes "1" and "2" from the "Digit Barcodes" section in Appendix.
 7. Scan the **Save** barcode from the "Save/Cancel Barcodes" section in Appendix.
 8. Scan the **Exit Setup** barcode.
-

China Post 25

Restore Factory Defaults



Restore the Factory Defaults of China Post 25

Enable/Disable China Post 25



Enable China Post 25



Disable China Post 25



If the scanner fails to identify China Post 25 barcodes, you may first try this solution by scanning the **Enter Setup** barcode and then **Enable China Post 25** barcode.

Set Length Range for China Post 25

The scanner can be configured to only decode China Post 25 barcodes with lengths that fall between (inclusive) the minimum and maximum lengths. To accomplish it, you need to set the minimum and maximum lengths.



Set the Minimum Length



Set the Maximum Length



If minimum length is set to be greater than maximum length, the scanner only decodes China Post 25 barcodes with either the minimum or maximum length. If minimum length is same as maximum length, only China Post 25 barcodes with that length are to be decoded.



Set the scanner to decode China Post 25 barcodes containing between 8 and 12 characters:

1. Scan the **Enter Setup** barcode.
 2. Scan the **Set the Minimum Length** barcode.
 3. Scan the numeric barcode "8" from the "Digit Barcodes" section in Appendix.
 4. Scan the **Save** barcode from the "Save/Cancel Barcodes" section in Appendix.
 5. Scan the **Set the Maximum Length** barcode.
 6. Scan the numeric barcodes "1" and "2" from the "Digit Barcodes" section in Appendix.
 7. Scan the **Save** barcode from the "Save/Cancel Barcodes" section in Appendix.
 8. Scan the **Exit Setup** barcode.
-

Check Character Verification

A check character is optional for China Post 25 and can be added as the last character. It is a calculated value used to verify the integrity of the data.

- ✧ **Disable:** The scanner transmits China Post 25 barcodes as is.
- ✧ **Do Not Transmit Check Character After Verification:** The scanner checks the integrity of all China Post 25 barcodes to verify that the data complies with the check character algorithm. Barcodes passing the check will be transmitted except the last digit, whereas those failing it will not be transmitted.
- ✧ **Transmit Check Character After Verification:** The scanner checks the integrity of all China Post 25 barcodes to verify that the data complies with the check character algorithm. Barcodes passing the check will be transmitted, whereas those failing it will not be transmitted.



Disable

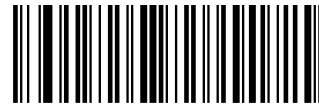

Do Not Transmit Check Character After Verification



Transmit Check Character After Verification



If the **Do Not Transmit Check Character After Verification** option is enabled, China Post 25 barcodes with a length that is less than the configured minimum length after having the check character excluded will not be decoded. (For example, when the **Do Not Transmit Check Character After Verification** option is enabled and the minimum length is set to 4, China Post 25 barcodes with a total length of 4 characters including the check character cannot be read.)

GS1-128 (UCC/EAN-128)

Restore Factory Defaults



@GS1DEF

Restore the Factory Defaults of GS1-128

Enable/Disable GS1-128



@GS1ENA1

Enable GS1-128



@GS1ENA0

Disable GS1-128



If the scanner fails to identify GS1-128 barcodes, you may first try this solution by scanning the **EnterSetup** barcode and then **Enable GS1-128** barcode.

Set Length Range for GS1-128

The scanner can be configured to only decode GS1-128 barcodes with lengths that fall between (inclusive) the minimum and maximum lengths. To accomplish it, you need to set the minimum and maximum lengths.



Set the Minimum Length



Set the Maximum Length



If minimum length is set to be greater than maximum length, the scanner only decodes GS1-128 barcodes with either the minimum or maximum length. If minimum length is same as maximum length, only GS1-128 barcodes with that length are to be decoded.



Set the scanner to decode GS1-128 barcodes containing between 8 and 12 characters:

1. Scan the **Enter Setup** barcode.
2. Scan the **Set the Minimum Length** barcode.
3. Scan the numeric barcode “8” from the “Digit Barcodes” section in Appendix.
4. Scan the **Save** barcode from the “Save/Cancel Barcodes” section in Appendix.
5. Scan the **Set the Maximum Length** barcode.
6. Scan the numeric barcodes “1” and “2” from the “Digit Barcodes” section in Appendix.
7. Scan the **Save** barcode from the “Save/Cancel Barcodes” section in Appendix.
8. Scan the **Exit Setup** barcode.

GS1 Databar (RSS)

Restore Factory Defaults



Restore the Factory Defaults of GS1 Databar

Enable/Disable GS1 Databar



Enable GS1 Databar



Disable GS1 Databar



If the scanner fails to identify GS1 Databar barcodes, you may first try this solution by scanning the **Enter Setup** barcode and then **Enable GS1 Databar** barcode.

Transmit Application Identifier “01”



Transmit Application Identifier “01”



Do Not Transmit Application Identifier “01”

GS1 Composite (EAN-UCC Composite)

Restore Factory Defaults



@CPTDEF

Restore the Factory Defaults of GS1 Composite

Enable/Disable GS1 Composite

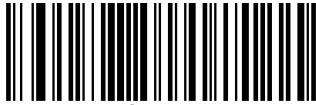

@CPTENA1

Enable GS1 Composite



@CPTENA0

Disable GS1 Composite



If the scanner fails to identify GS1 Composite barcodes, you may first try this solution by scanning the **Enter Setup** barcode and then **Enable GS1 Composite** barcode.

Enable/Disable UPC/EAN Composite



Enable UPC/EAN Composite



Disable UPC/EAN Composite

Code 11

Restore Factory Defaults



@C11DEF

Restore the Factory Defaults of Code 11

Enable/Disable Code 11



@C11ENA1

Enable Code 11



@C11ENA0

Disable Code 11



If the scanner fails to identify Code 11 barcodes, you may first try this solution by scanning the **Enter Setup** barcode and then **Enable Code 11** barcode.

Set Length Range for Code 11

The scanner can be configured to only decode Code 11 barcodes with lengths that fall between (inclusive) the minimum and maximum lengths. To accomplish it, you need to set the minimum and maximum lengths.



Set the Minimum Length



Set the Maximum Length



If minimum length is set to be greater than maximum length, the scanner only decodes Code 11 barcodes with either the minimum or maximum length. If minimum length is same as maximum length, only Code 11 barcodes with that length are to be decoded.



Set the scanner to decode Code 11 barcodes containing between 8 and 12 characters:

1. Scan the **Enter Setup** barcode.
2. Scan the **Set the Minimum Length** barcode.
3. Scan the numeric barcode "8" from the "Digit Barcodes" section in Appendix.
4. Scan the **Save** barcode from the "Save/Cancel Barcodes" section in Appendix.
5. Scan the **Set the Maximum Length** barcode.
6. Scan the numeric barcodes "1" and "2" from the "Digit Barcodes" section in Appendix.
7. Scan the **Save** barcode from the "Save/Cancel Barcodes" section in Appendix.
8. Scan the **Exit Setup** barcode.

Check Character Verification

Check characters are optional for Code 11 and can be added as the last one or two characters, which are calculated values used to verify the integrity of the data.

If the **Disable** option is enabled, the scanner transmits Code 11 barcodes as is.



@C11CHK0

Disable



@C11CHK1

One Check Character, MOD11



@C11CHK2

Two Check Characters, MOD11/MOD11



@C11CHK3

Two Check Characters, MOD11/MOD9



@C11CHK4

One Check Character, MOD11 (Len<=10)

Two Check Characters, MOD11/MOD11(Len>10)



@C11CHK5

One Check Character, MOD11 (Len<=10)

Two Check Characters, MOD11/MOD9 (Len>10)

Transmit Check Character



@C11TCK0

Do Not Transmit Code 11 Check Character



@C11TCK1

Transmit Code 11 Check Character



If you select a check character algorithm and the **Do Not Transmit Check Character** option, Code 11 barcodes with a length that is less than the configured minimum length after having the check character(s) excluded will not be decoded. (For example, when the **One Check Character, MOD11** and **Do Not Transmit Check Character** options are enabled and the minimum length is set to 4, Code 11 barcodes with a total length of 4 characters including the check character cannot be read.)

ISBN

Restore Factory Defaults



@ISBDEF

Restore the Factory Defaults of ISBN

Enable/Disable ISBN



@ISBENA1

Enable ISBN



@ISBENA0

Disable ISBN



If the scanner fails to identify ISBN barcodes, you may first try this solution by scanning the **Enter Setup** barcode and then **Enable ISBN** barcode.

Set ISBN Format



@ISBT101
ISBN-10



@ISBT100
ISBN-13

ISSN

Restore Factory Defaults



@ISSDEF

Restore the Factory Defaults of ISSN

Enable/Disable ISSN



@ISSENA1

Enable ISSN



@ISSENA0

Disable ISSN



If the scanner fails to identify ISSN barcodes, you may first try this solution by scanning the **Enter Setup** barcode and then **Enable ISSN** barcode.

Industrial 25

Restore Factory Defaults



@L25DEF

Restore the Factory Defaults of Industrial 25

Enable/Disable Industrial 25



@L25ENA1

Enable Industrial 25



@L25ENA0

Disable Industrial 25



If the scanner fails to identify Industrial 25 barcodes, you may first try this solution by scanning the **Enter Setup** barcode and then **Enable Industrial 25** barcode.

Set Length Range for Industrial 25

The scanner can be configured to only decode Industrial 25 barcodes with lengths that fall between (inclusive) the minimum and maximum lengths. To accomplish it, you need to set the minimum and maximum lengths.



Set the Minimum Length



Set the Maximum Length



If minimum length is set to be greater than maximum length, the scanner only decodes Industrial 25 barcodes with either the minimum or maximum length. If minimum length is same as maximum length, only Industrial 25 barcodes with that length are to be decoded.



Set the scanner to decode Industrial 25 barcodes containing between 8 and 12 characters:

1. Scan the **Enter Setup** barcode.
2. Scan the **Set the Minimum Length** barcode.
3. Scan the numeric barcode “8” from the “Digit Barcodes” section in Appendix.
4. Scan the **Save** barcode from the “Save/Cancel Barcodes” section in Appendix.
5. Scan the **Set the Maximum Length** barcode.
6. Scan the numeric barcodes “1” and “2” from the “Digit Barcodes” section in Appendix.
7. Scan the **Save** barcode from the “Save/Cancel Barcodes” section in Appendix.
8. Scan the **Exit Setup** barcode.

Check Character Verification

A check character is optional for Industrial 25 and can be added as the last character. It is a calculated value used to verify the integrity of the data.

- ✧ **Disable:** The scanner transmits Industrial 25 barcodes as is.
- ✧ **Do Not Transmit Check Character After Verification:** The scanner checks the integrity of all Industrial 25 barcodes to verify that the data complies with the check character algorithm. Barcodes passing the check will be transmitted except the last digit, whereas those failing it will not be transmitted.
- ✧ **Transmit Check Character After Verification:** The scanner checks the integrity of all Industrial 25 barcodes to verify that the data complies with the check character algorithm. Barcodes passing the check will be transmitted, whereas those failing it will not be transmitted.

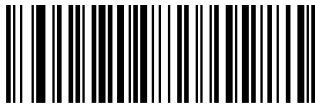

Disable

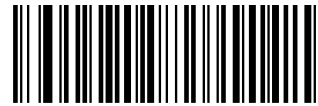

Do Not Transmit Check Character After Verification



Transmit Check Character After Verification



If the **Do Not Transmit Check Character After Verification** option is enabled, Industrial 25 barcodes with a length that is less than the configured minimum length after having the check character excluded will not be decoded. (For example, when the **Do Not Transmit Check Character After Verification** option is enabled and the minimum length is set to 4, Industrial 25 barcodes with a total length of 4 characters including the check character cannot be read.)

Standard 25

Restore Factory Defaults



@S25DEF

Restore the Factory Defaults of Standard 25

Enable/Disable Standard 25



@S25ENA1

Enable Standard 25



@S25ENA0

Disable Standard 25



If the scanner fails to identify Standard 25 barcodes, you may first try this solution by scanning the **Enter Setup** barcode and then **Enable Standard 25** barcode.

Set Length Range for Standard 25

The scanner can be configured to only decode Standard 25 barcodes with lengths that fall between (inclusive) the minimum and maximum lengths. To accomplish it, you need to set the minimum and maximum lengths.



Set the Minimum Length



Set the Maximum Length



If minimum length is set to be greater than maximum length, the scanner only decodes Standard 25 barcodes with either the minimum or maximum length. If minimum length is same as maximum length, only Standard 25 barcodes with that length are to be decoded.



Set the scanner to decode Standard 25 barcodes containing between 8 and 12 characters:

1. Scan the **Enter Setup** barcode.
 2. Scan the **Set the Minimum Length** barcode.
 3. Scan the numeric barcode “8” from the “Digit Barcodes” section in Appendix.
 4. Scan the **Save** barcode from the “Save/Cancel Barcodes” section in Appendix.
 5. Scan the **Set the Maximum Length** barcode.
 6. Scan the numeric barcodes “1” and “2” from the “Digit Barcodes” section in Appendix.
 7. Scan the **Save** barcode from the “Save/Cancel Barcodes” section in Appendix.
 8. Scan the **Exit Setup** barcode.
-

Check Character Verification

A check character is optional for Standard 25 and can be added as the last character. It is a calculated value used to verify the integrity of the data.

- ✧ **Disable:** The scanner transmits Standard 25 barcodes as is.
- ✧ **Do Not Transmit Check Character After Verification:** The scanner checks the integrity of all Standard 25 barcodes to verify that the data complies with the check character algorithm. Barcodes passing the check will be transmitted except the last digit, whereas those failing it will not be transmitted.
- ✧ **Transmit Check Character After Verification:** The scanner checks the integrity of all Standard 25 barcodes to verify that the data complies with the check character algorithm. Barcodes passing the check will be transmitted, whereas those failing it will not be transmitted.



Disable



Do Not Transmit Check Character After Verification



Transmit Check Character After Verification



If the **Do Not Transmit Check Character After Verification** option is enabled, Standard 25 barcodes with a length that is less than the configured minimum length after having the check character excluded will not be decoded. (For example, when the **Do Not Transmit Check Character After Verification** option is enabled and the minimum length is set to 4, Standard 25 barcodes with a total length of 4 characters including the check character cannot be read.)

Plessey

Restore Factory Defaults



@PLYDEF

Restore the Factory Defaults of Plessey

Enable/Disable Plessey



@PLYENA1

Enable Plessey



@PLYENA0

Disable Plessey



If the scanner fails to identify Plessey barcodes, you may first try this solution by scanning the **Enter Setup** barcode and then **Enable Plessey** barcode.

Set Length Range for Plessey

The scanner can be configured to only decode Plessey barcodes with lengths that fall between (inclusive) the minimum and maximum lengths. To accomplish it, you need to set the minimum and maximum lengths.



Set the Minimum Length



Set the Maximum Length



If minimum length is set to be greater than maximum length, the scanner only decodes Plessey barcodes with either the minimum or maximum length. If minimum length is same as maximum length, only Plessey barcodes with that length are to be decoded.



Set the scanner to decode Plessey barcodes containing between 8 and 12 characters:

1. Scan the **Enter Setup** barcode.
 2. Scan the **Set the Minimum Length** barcode.
 3. Scan the numeric barcode “8” from the “Digit Barcodes” section in Appendix.
 4. Scan the **Save** barcode from the “Save/Cancel Barcodes” section in Appendix.
 5. Scan the **Set the Maximum Length** barcode.
 6. Scan the numeric barcodes “1” and “2” from the “Digit Barcodes” section in Appendix.
 7. Scan the **Save** barcode from the “Save/Cancel Barcodes” section in Appendix.
 8. Scan the **Exit Setup** barcode.
-

Check Character Verification

Check characters are optional for Plessey and can be added as the last two characters, which are calculated values used to verify the integrity of the data.

- ✧ **Disable:** The scanner transmits Plessey barcodes as is.
- ✧ **Do Not Transmit Check Character After Verification:** The scanner checks the integrity of all Plessey barcodes to verify that the data complies with the check character algorithm. Barcodes passing the checks will be transmitted except the last two digits, whereas those failing them will not be transmitted.
- ✧ **Transmit Check Character After Verification:** The scanner checks the integrity of all Plessey barcodes to verify that the data complies with the check character algorithm. Barcodes passing the checks will be transmitted, whereas those failing them will not be transmitted.



Disable



Do Not Transmit Check Character After Verification



Transmit Check Character After Verification



If the **Do Not Transmit Check Character After Verification** option is enabled, Plessey barcodes with a length that is less than the configured minimum length after having the check characters excluded will not be decoded. (For example, when the **Do Not Transmit Check Character After Verification** option is enabled and the minimum length is set to 4, Plessey barcodes with a total length of 4 characters including the check characters cannot be read.)

MSI-Plessey

Restore Factory Defaults



@MSIDF

Restore the Factory Defaults of MSI-Plessey

Enable/Disable MSI-Plessey



@MSIENA1

Enable MSI-Plessey



@MSIENA0

Disable MSI-Plessey



If the scanner fails to identify MSI-Plessey barcodes, you may first try this solution by scanning the **Enter Setup** barcode and then **Enable MSI-Plessey** barcode.

Set Length Range for MSI-Plessey

The scanner can be configured to only decode MSI-Plessey barcodes with lengths that fall between (inclusive) the minimum and maximum lengths. To accomplish it, you need to set the minimum and maximum lengths.



Set the Minimum Length



Set the Maximum Length



If minimum length is set to be greater than maximum length, the scanner only decodes MSI-Plessey barcodes with either the minimum or maximum length. If minimum length is same as maximum length, only MSI-Plessey barcodes with that length are to be decoded.



Set the scanner to decode MSI-Plessey barcodes containing between 8 and 12 characters:

1. Scan the **Enter Setup** barcode.
 2. Scan the **Set the Minimum Length** barcode.
 3. Scan the numeric barcode "8" from the "Digit Barcodes" section in Appendix.
 4. Scan the **Save** barcode from the "Save/Cancel Barcodes" section in Appendix.
 5. Scan the **Set the Maximum Length** barcode.
 6. Scan the numeric barcodes "1" and "2" from the "Digit Barcodes" section in Appendix.
 7. Scan the **Save** barcode from the "Save/Cancel Barcodes" section in Appendix.
 8. Scan the **Exit Setup** barcode.
-

Check Character Verification

Check characters are optional for MSI-Plessey and can be added as the last one or two characters, which are calculated values used to verify the integrity of the data.

If the **Disable** option is enabled, the scanner transmits MSI-Plessey barcodes as is.



Disable



One Check Character, MOD10



Two Check Characters, MOD10/MOD10



Two Check Characters, MOD10/MOD11

Transmit Check Character



Transmit MSI-Plessey Check Character



Do Not Transmit MSI-Plessey Check Character



If you select a check character algorithm and the **Do Not Transmit Check Character** option, MSI-Plessey barcodes with a length that is less than the configured minimum length after having the check character(s) excluded will not be decoded. (For example, when the **One Check Character, MOD10** and **Do Not Transmit Check Character** options are enabled and the minimum length is set to 4, MSI-Plessey barcodes with a total length of 4 characters including the check character cannot be read.)

AIM 128

Restore Factory Defaults



@AIMDEF

Restore the Factory Defaults of AIM 128

Enable/Disable AIM 128



@AIMENA1

Enable AIM 128



@AIMENA0

Disable AIM 128



If the scanner fails to identify AIM 128 barcodes, you may first try this solution by scanning the **Enter Setup** barcode and then **Enable AIM 128** barcode.

Set Length Range for AIM 128

The scanner can be configured to only decode AIM 128 barcodes with lengths that fall between (inclusive) the minimum and maximum lengths. To accomplish it, you need to set the minimum and maximum lengths.



Set the Minimum Length



Set the Maximum Length



If minimum length is set to be greater than maximum length, the scanner only decodes AIM 128 barcodes with either the minimum or maximum length. If minimum length is same as maximum length, only AIM 128 barcodes with that length are to be decoded.



Set the scanner to decode AIM 128 barcodes containing between 8 and 12 characters:

1. Scan the **Enter Setup** barcode.
2. Scan the **Set the Minimum Length** barcode.
3. Scan the numeric barcode "8" from the "Digit Barcodes" section in Appendix.
4. Scan the **Save** barcode from the "Save/Cancel Barcodes" section in Appendix.
5. Scan the **Set the Maximum Length** barcode.
6. Scan the numeric barcodes "1" and "2" from the "Digit Barcodes" section in Appendix.
7. Scan the **Save** barcode from the "Save/Cancel Barcodes" section in Appendix.
8. Scan the **Exit Setup** barcode.

ISBT 128

Restore Factory Defaults



@IBTDEF

Restore the Factory Defaults of ISBT 128

Enable/Disable ISBT 128



@IBTENA1

Enable ISBT 128



@IBTENA0

Disable ISBT 128



If the scanner fails to identify ISBT 128 barcodes, you may first try this solution by scanning the **Enter Setup** barcode and then **Enable ISBT 128** barcode.

Code 49

Restore Factory Defaults



@C49DEF

Restore the Factory Defaults of Code 49

Enable/Disable Code 49



@C49ENA1

Enable Code 49



@C49ENA0

Disable Code 49



If the scanner fails to identify Code 49 barcodes, you may first try this solution by scanning the **Enter Setup** barcode and then **Enable Code 49** barcode.

Set Length Range for Code 49

The scanner can be configured to only decode Code 49 barcodes with lengths that fall between (inclusive) the minimum and maximum lengths. To accomplish it, you need to set the minimum and maximum lengths.



Set the Minimum Length



Set the Maximum Length



If minimum length is set to be greater than maximum length, the scanner only decodes Code 49 barcodes with either the minimum or maximum length. If minimum length is same as maximum length, only Code 49 barcodes with that length are to be decoded.



Set the scanner to decode Code 49 barcodes containing between 8 and 12 characters:

1. Scan the **Enter Setup** barcode.
 2. Scan the **Set the Minimum Length** barcode.
 3. Scan the numeric barcode "8" from the "Digit Barcodes" section in Appendix.
 4. Scan the **Save** barcode from the "Save/Cancel Barcodes" section in Appendix.
 5. Scan the **Set the Maximum Length** barcode.
 6. Scan the numeric barcodes "1" and "2" from the "Digit Barcodes" section in Appendix.
 7. Scan the **Save** barcode from the "Save/Cancel Barcodes" section in Appendix.
 8. Scan the **Exit Setup** barcode.
-

Code 16K

Restore Factory Defaults



@16KDEF

Restore the Factory Defaults of Code 16K

Enable/Disable Code 16K



@16KENA1

Enable Code 16K



@16KENA0

Disable Code 16K



If the scanner fails to identify Code 16K barcodes, you may first try this solution by scanning the **Enter Setup** barcode and then **Enable Code 16K** barcode.

Set Length Range for Code 16K

The scanner can be configured to only decode Code 16K barcodes with lengths that fall between (inclusive) the minimum and maximum lengths. To accomplish it, you need to set the minimum and maximum lengths.



Set the Minimum Length



Set the Maximum Length



If minimum length is set to be greater than maximum length, the scanner only decodes Code 16K barcodes with either the minimum or maximum length. If minimum length is same as maximum length, only Code 16K barcodes with that length are to be decoded.



Set the scanner to decode Code 16K barcodes containing between 8 and 12 characters:

1. Scan the **Enter Setup** barcode.
2. Scan the **Set the Minimum Length** barcode.
3. Scan the numeric barcode "8" from the "Digit Barcodes" section in Appendix.
4. Scan the **Save** barcode from the "Save/Cancel Barcodes" section in Appendix.
5. Scan the **Set the Maximum Length** barcode.
6. Scan the numeric barcodes "1" and "2" from the "Digit Barcodes" section in Appendix.
7. Scan the **Save** barcode from the "Save/Cancel Barcodes" section in Appendix.
8. Scan the **Exit Setup** barcode.

Pharmacode

Restore Factory Defaults



Restore the Factory Defaults of Pharmacode

Enable/Disable Pharmacode

When the Pharmacode is enabled, other symbologies will be automatically disabled



Enable Pharmacode



Disable Pharmacode



If the scanner fails to identify **Pharmacode** barcodes, you may first try this solution by scanning the **Enter Setup** barcode and then **Enable Pharmacode** barcode.

Pharmacode One-Track

Enable/Disable Pharmacode One-Track



Enable Pharmacode One-Track



Disable Pharmacode One-Track

Set Pharmacode One-Track Decoding Direction



Left to Right



Right to Left



Upward



Downward

Set the Number of Pharmacode One-Track



Set the Minimum Number



Set the Maximum Number



The maximum number of 1D barcode must not exceed 16. If the maximum number of barcode is same as the minimum number, only barcode with that number are to be decoded

Set the scanner to decode between 2 and 12 Pharmacode One-Track barcodes.

1. Scan the **Enter Setup** barcode.
2. Scan the **Set the Minimum Number** barcode.
3. Scan the numeric barcode "2" from the "Digit Barcodes" section in Appendix.
4. Scan the **Save** barcode from the "Save/Cancel Barcodes" section in Appendix.
5. Scan the **Set the Maximum Number** barcode.
6. Scan the numeric barcodes "1" and "2" from the "Digit Barcodes" section in Appendix.
7. Scan the **Save** barcode from the "Save/Cancel Barcodes" section in Appendix.
8. Scan the **Exit Setup** barcode.

Pharmacode One-Track Inverse



**Decode Regular Pharmacode One-Track
Barcodes Only**



**Decode Inverse Pharmacode One-Track
Barcodes Only**



Decode Both

Set Pharmacode One-Track Quiet Zone



Set Quiet Zone

Set Pharmacode One-Track Output Format



Normal Format



Binary Format

Pharmacode Two-Track

Enable/Disable Pharmacode Two-Track



Enable Pharmacode Two-Track



Disable Pharmacode Two-Track

Set Pharmacode Two-Track Decoding Direction



Left to Right



Right to Left



Upward



Downward

Set the Number of Pharmacode Two-Track



Set the Minimum Number



Set the Maximum Number



The maximum number of 1D barcode must not exceed 16. If the maximum number of barcode is same as the minimum number, only barcode with that number are to be decoded



Set the scanner to decode between 2 and 12 Pharmacode Two-Track barcodes.

1. Scan the **Enter Setup** barcode.
2. Scan the **Set the Minimum Number** barcode.
3. Scan the numeric barcode "2" from the "Digit Barcodes" section in Appendix.
4. Scan the **Save** barcode from the "Save/Cancel Barcodes" section in Appendix.
5. Scan the **Set the Maximum Number** barcode.
6. Scan the numeric barcodes "1" and "2" from the "Digit Barcodes" section in Appendix.
7. Scan the **Save** barcode from the "Save/Cancel Barcodes" section in Appendix.
8. Scan the **Exit Setup** barcode.

Pharmacode Two-Track Inverse



@PHCTIV0

**Decode Regular Pharmacode Two-Track
Barcodes Only**



@PHCTIV1

**Decode Inverse Pharmacode Two-Track
Barcodes Only**



@PHCTIV2

Decode Both

Set Pharmacode Two-Track Quiet Zone



@PHCTQS

Set Quiet Zone

Set Pharmacode Two-Track Output Format



@PHCTFM0

Normal Format



@PHCTFM1

Binary Format

PDF417

Restore Factory Defaults



Restore the Factory Defaults of PDF417

Enable/Disable PDF417



Enable PDF417



Disable PDF417



If the scanner fails to identify PDF417 barcodes, you may first try this solution by scanning the **Enter Setup** barcode and then **Enable PDF417** barcode.

Set Length Range for PDF417

The scanner can be configured to only decode PDF417 barcodes with lengths that fall between (inclusive) the minimum and maximum lengths. To accomplish it, you need to set the minimum and maximum lengths.



Set the Minimum Length



Set the Maximum Length



Minimum length is not allowed to be greater than maximum length. If you only want to read PDF417 barcodes with a specific length, set both minimum and maximum lengths to be that desired length.



Set the scanner to decode PDF417 barcodes containing between 8 and 12 characters:

1. Scan the **Enter Setup** barcode.
2. Scan the **Set the Minimum Length** barcode.
3. Scan the numeric barcode “8” from the “Digit Barcodes” section in Appendix.
4. Scan the **Save** barcode from the “Save/Cancel Barcodes” section in Appendix.
5. Scan the **Set the Maximum Length** barcode.
6. Scan the numeric barcodes “1” and “2” from the “Digit Barcodes” section in Appendix.
7. Scan the **Save** barcode from the “Save/Cancel Barcodes” section in Appendix.
8. Scan the **Exit Setup** barcode.

PDF417 Inverse

Regular barcode: Dark bars on a bright background.

Inverse barcode: Bright bars on a dark background.



@PDFINV0

Decode Regular PDF417 Barcodes Only



@PDFINV1

Decode Inverse PDF417 Barcodes Only



@PDFINV2

Decode Both

Character Encoding



@PDFENC0

Default Character Encoding



@PDFENC1

UTF-8



@PDFENC2

Automatically Select UTF-8 or Code Page

PDF417 ECI Output



@PDFECI0

Disable PDF417 ECI Output



@PDFECI1

Enable PDF417 ECI Output

Micro PDF417

Restore Factory Defaults



@MPDDEF

Restore the Factory Defaults of Micro PDF417

Enable/Disable Micro PDF417



@MPDENA1

Enable Micro PDF417



@MPDENA0

Disable Micro PDF417



If the scanner fails to identify Micro PDF417 barcodes, you may first try this solution by scanning the **Enter Setup** barcode and then **Enable Micro PDF417** barcode.

Set Length Range for Micro PDF417

The scanner can be configured to only decode Micro PDF417 barcodes with lengths that fall between (inclusive) the minimum and maximum lengths. To accomplish it, you need to set the minimum and maximum lengths.



Set the Minimum Length



Set the Maximum Length



Minimum length is not allowed to be greater than maximum length. If you only want to read Micro PDF417 barcodes with a specific length, set both minimum and maximum lengths to be that desired length.



Set the scanner to decode Micro PDF417 barcodes containing between 8 and 12 characters:

1. Scan the **Enter Setup** barcode.
2. Scan the **Set the Minimum Length** barcode.
3. Scan the numeric barcode “8” from the “Digit Barcodes” section in Appendix.
4. Scan the **Save** barcode from the “Save/Cancel Barcodes” section in Appendix.
5. Scan the **Set the Maximum Length** barcode.
6. Scan the numeric barcodes “1” and “2” from the “Digit Barcodes” section in Appendix.
7. Scan the **Save** barcode from the “Save/Cancel Barcodes” section in Appendix.
8. Scan the **Exit Setup** barcode.

QR Code

Restore Factory Defaults



@QRCDEF

Restore the Factory Defaults of QR Code

Enable/Disable QR Code



@QRCENA1

Enable QR Code



@QRCENA0

Disable QR Code



If the scanner fails to identify QR Code barcodes, you may first try this solution by scanning the **Enter Setup** barcode and then **Enable QR Code** barcode.

Set Length Range for QR Code

The scanner can be configured to only decode QR Code barcodes with lengths that fall between (inclusive) the minimum and maximum lengths. To accomplish it, you need to set the minimum and maximum lengths.



Set the Minimum Length



Set the Maximum Length



Minimum length is not allowed to be greater than maximum length. If you only want to read QR Code barcodes with a specific length, set both minimum and maximum lengths to be that desired length.



Set the scanner to decode QR Code barcodes containing between 8 and 12 characters:

1. Scan the **Enter Setup** barcode.
2. Scan the **Set the Minimum Length** barcode.
3. Scan the numeric barcode "8" from the "Digit Barcodes" section in Appendix.
4. Scan the **Save** barcode from the "Save/Cancel Barcodes" section in Appendix.
5. Scan the **Set the Maximum Length** barcode.
6. Scan the numeric barcodes "1" and "2" from the "Digit Barcodes" section in Appendix.
7. Scan the **Save** barcode from the "Save/Cancel Barcodes" section in Appendix.
8. Scan the **Exit Setup** barcode.

QR Inverse

Regular barcode: Dark bars on a bright background.

Inverse barcode: Bright bars on a dark background.



Decode Regular QR Barcodes Only



Decode Inverse QR Barcodes Only



Decode Both

Character Encoding



Default Character Encoding



UTF-8



Automatically Select UTF-8 or Code Page

QR ECI Output



@QRCECI0

Disable QR ECI Output



@QRCECI1

Enable QR ECI Output

URL QR

URL QR code refers to QR code whose barcode data begins with the http or HTTP.



@QRCURL0

Disable URL QR



@QRCURL1

Enable URL QR

- ◆ **Custom URL QR**

You can append to the QR barcode data several user-defined strings (separated by "|") that cannot exceed 64 characters, including separators (HEX values from 0x00 to 0xFF). When URL QR is enabled, the scanner will not read the QR code whose barcode data starts with custom strings.



Custom URL QR

Micro QR Code

Restore Factory Defaults



@MQRDEF

Restore the Factory Defaults of Micro QR

Enable/Disable Micro QR



@MQRENA1

Enable Micro QR



@MQRENA0

Disable Micro QR



If the scanner fails to identify Micro QR barcodes, you may first try this solution by scanning the **Enter Setup** barcode and then **Enable Micro QR** barcode.

Set Length Range for Micro QR

The scanner can be configured to only decode Micro QR barcodes with lengths that fall between (inclusive) the minimum and maximum lengths. To accomplish it, you need to set the minimum and maximum lengths.



Set the Minimum Length



Set the Maximum Length



Minimum length is not allowed to be greater than maximum length. If you only want to read Micro QR barcodes with a specific length, set both minimum and maximum lengths to be that desired length.



Set the scanner to decode Micro QR Code barcodes containing between 8 and 12 characters:

1. Scan the **Enter Setup** barcode.
2. Scan the **Set the Minimum Length** barcode.
3. Scan the numeric barcode “8” from the “Digit Barcodes” section in Appendix.
4. Scan the **Save** barcode from the “Save/Cancel Barcodes” section in Appendix.
5. Scan the **Set the Maximum Length** barcode.
6. Scan the numeric barcodes “1” and “2” from the “Digit Barcodes” section in Appendix.
7. Scan the **Save** barcode from the “Save/Cancel Barcodes” section in Appendix.
8. Scan the **Exit Setup** barcode.

Aztec

Restore Factory Defaults



Restore the Factory Defaults of Aztec Code

Enable/Disable Aztec Code



Enable Aztec Code



Disable Aztec Code



If the scanner fails to identify Aztec Code barcodes, you may first try this solution by scanning the **Enter Setup** barcode and then **Enable Aztec Code** barcode.

Set Length Range for Aztec Code

The scanner can be configured to only decode Aztec barcodes with lengths that fall between (inclusive) the minimum and maximum lengths. To accomplish it, you need to set the minimum and maximum lengths.



Set the Minimum Length



Set the Maximum Length



Minimum length is not allowed to be greater than maximum length. If you only want to read Aztec barcodes with a specific length, set both minimum and maximum lengths to be that desired length.



Set the scanner to decode Aztec barcodes containing between 8 and 12 characters:

1. Scan the **Enter Setup** barcode.
 2. Scan the **Set the Minimum Length** barcode.
 3. Scan the numeric barcode "8" from the "Digit Barcodes" section in Appendix.
 4. Scan the **Save** barcode from the "Save/Cancel Barcodes" section in Appendix.
 5. Scan the **Set the Maximum Length** barcode.
 6. Scan the numeric barcodes "1" and "2" from the "Digit Barcodes" section in Appendix.
 7. Scan the **Save** barcode from the "Save/Cancel Barcodes" section in Appendix.
 8. Scan the **Exit Setup** barcode.
-

Aztec Inverse

Regular barcode: Dark bars on a bright background.

Inverse barcode: Bright bars on a dark background.



Decode Regular Aztec Barcodes Only



Decode Inverse Aztec Barcodes Only



Decode Both

Character Encoding



@AZTENC0

Default Character Encoding



@AZTENC1

UTF-8



@AZTENC2

Automatically Select UTF-8 or Code Page

Aztec ECI Output



@AZTEC10

Disable Aztec ECI Output



@AZTEC11

Enable Aztec ECI Output

Data Matrix

Restore Factory Defaults



@DMCDEF

Restore the Factory Defaults of Data Matrix

Enable/Disable Data Matrix



@DMCENA1

Enable Data Matrix



@DMCENA0

Disable Data Matrix



If the scanner fails to identify Data Matrix barcodes, you may first try this solution by scanning the **Enter Setup** barcode and then **Enable Data Matrix** barcode.

Set Length Range for Data Matrix

The scanner can be configured to only decode Data Matrix barcodes with lengths that fall between (inclusive) the minimum and maximum lengths. To accomplish it, you need to set the minimum and maximum lengths.



Set the Minimum Length



Set the Maximum Length



Minimum length is not allowed to be greater than maximum length. If you only want to read Data Matrix barcodes with a specific length, set both minimum and maximum lengths to be that desired length.



Set the scanner to decode Data Matrix barcodes containing between 8 and 12 characters:

1. Scan the **Enter Setup** barcode.
2. Scan the **Set the Minimum Length** barcode.
3. Scan the numeric barcode "8" from the "Digit Barcodes" section in Appendix.
4. Scan the **Save** barcode from the "Save/Cancel Barcodes" section in Appendix.
5. Scan the **Set the Maximum Length** barcode.
6. Scan the numeric barcodes "1" and "2" from the "Digit Barcodes" section in Appendix.
7. Scan the **Save** barcode from the "Save/Cancel Barcodes" section in Appendix.
8. Scan the **Exit Setup** barcode.

Rectangular Barcode

Data Matrix has two formats:

Square barcodes having the same amount of modules in length and width: 10*10, 12*12.... 144*144.

Rectangular barcodes having different amounts of models in length and width: 6*16, 6*14...14*22.



Enable Rectangular Barcode



Disable Rectangular Barcode

Data Matrix Inverse

Regular barcode: Dark bars on a bright background.

Inverse barcode: Bright bars on a dark background.



Decode Regular Data Matrix Barcodes Only



Decode Inverse Data Matrix Barcodes Only



Decode Both

Character Encoding



@DMCENC0

Default Character Encoding



@DMCENC1

UTF-8



@DMCENC2

Automatically Select UTF-8 or Code Page

Data Matrix ECI Output



@DMCEC10

Disable Data Matrix ECI Output



@DMCEC11

Enable Data Matrix ECI Output

Maxicode

Restore Factory Defaults



@MXCDEF

Restore the Factory Defaults of Maxicode

Enable/Disable Maxicode



@MXCENA1

Enable Maxicode



@MXCENA0

Disable Maxicode



If the scanner fails to identify Maxicode barcodes, you may first try this solution by scanning the **Enter Setup** barcode and then **Enable Maxicode** barcode.

Set Length Range for Maxicode

The scanner can be configured to only decode Maxicode barcodes with lengths that fall between (inclusive) the minimum and maximum lengths. To accomplish it, you need to set the minimum and maximum lengths.



Set the Minimum Length



Set the Maximum Length



Minimum length is not allowed to be greater than maximum length. If you only want to read Maxicode barcodes with a specific length, set both minimum and maximum lengths to be that desired length.



Set the scanner to decode Maxicode barcodes containing between 8 and 12 characters:

1. Scan the **Enter Setup** barcode.
2. Scan the **Set the Minimum Length** barcode.
3. Scan the numeric barcode “8” from the “Digit Barcodes” section in Appendix.
4. Scan the **Save** barcode from the “Save/Cancel Barcodes” section in Appendix.
5. Scan the **Set the Maximum Length** barcode.
6. Scan the numeric barcodes “1” and “2” from the “Digit Barcodes” section in Appendix.
7. Scan the **Save** barcode from the “Save/Cancel Barcodes” section in Appendix.
8. Scan the **Exit Setup** barcode.

Chinese Sensible Code

Restore Factory Defaults



@CSCDEF
Restore the Factory Defaults of Chinese Sensible Code

Enable/Disable Chinese Sensible Code



@CSCENA1
Enable Chinese Sensible Code



@CSCENA0
Disable Chinese Sensible Code



If the scanner fails to identify Chinese Sensible Code barcodes, you may first try this solution by scanning the **Enter Setup** barcode and then **Enable Chinese Sensible Code** barcode.

Set Length Range for Chinese Sensible Code

The scanner can be configured to only decode Chinese Sensible Code barcodes with lengths that fall between (inclusive) the minimum and maximum lengths. To accomplish it, you need to set the minimum and maximum lengths.



Set the Minimum Length



Set the Maximum Length



Minimum length is not allowed to be greater than maximum length. If you only want to read Chinese Sensible Code barcodes with a specific length, set both minimum and maximum lengths to be that desired length.



Set the scanner to decode Chinese Sensible Code barcodes containing between 8 and 12 characters:

1. Scan the **Enter Setup** barcode.
2. Scan the **Set the Minimum Length** barcode.
3. Scan the numeric barcode "8" from the "Digit Barcodes" section in Appendix.
4. Scan the **Save** barcode from the "Save/Cancel Barcodes" section in Appendix.
5. Scan the **Set the Maximum Length** barcode.
6. Scan the numeric barcodes "1" and "2" from the "Digit Barcodes" section in Appendix.
7. Scan the **Save** barcode from the "Save/Cancel Barcodes" section in Appendix.
8. Scan the **Exit Setup** barcode.

Chinese Sensible Code Inverse

Regular barcode: Dark bars on a bright background.

Inverse barcode: Bright bars on a dark background.



@CSCINV0

Decode Regular Chinese Sensible Barcodes Only



@CSCINV1

Decode Inverse Chinese Sensible Barcodes Only



@CSCINV2

Decode Both

GM Code

Restore Factory Defaults



@GMCDEF

Restore the Factory Defaults of GM

Enable/Disable GM



@GMCENA1

Enable GM



@GMCENA0

Disable GM



If the scanner fails to identify GM barcodes, you may first try this solution by scanning the **Enter Setup** barcode and then **Enable GM** barcode.

Set Length Range for GM

The scanner can be configured to only decode GM barcodes with lengths that fall between (inclusive) the minimum and maximum lengths. To accomplish it, you need to set the minimum and maximum lengths.



Set the Minimum Length



Set the Maximum Length



Minimum length is not allowed to be greater than maximum length. If you only want to read GM barcodes with a specific length, set both minimum and maximum lengths to be that desired length.



Set the scanner to decode GM barcodes containing between 8 and 12 characters:

1. Scan the **Enter Setup** barcode.
2. Scan the **Set the Minimum Length** barcode.
3. Scan the numeric barcode "8" from the "Digit Barcodes" section in Appendix.
4. Scan the **Save** barcode from the "Save/Cancel Barcodes" section in Appendix.
5. Scan the **Set the Maximum Length** barcode.
6. Scan the numeric barcodes "1" and "2" from the "Digit Barcodes" section in Appendix.
7. Scan the **Save** barcode from the "Save/Cancel Barcodes" section in Appendix.
8. Scan the **Exit Setup** barcode.

Code One

Restore Factory Defaults



@ONEDEF

Restore the Factory Defaults of Code One

Enable/Disable Code One



@ONEENA1

Enable Code One



@ONEENA0

Disable Code One



If the scanner fails to identify Code One barcodes, you may first try this solution by scanning the **Enter Setup** barcode and then **Enable Code One** barcode.

Set Length Range for Code One

The scanner can be configured to only decode Code One barcodes with lengths that fall between (inclusive) the minimum and maximum lengths. To accomplish it, you need to set the minimum and maximum lengths.



Set the Minimum Length



Set the Maximum Length



Minimum length is not allowed to be greater than maximum length. If you only want to read Code One barcodes with a specific length, set both minimum and maximum lengths to be that desired length.



Set the scanner to decode Code One barcodes containing between 8 and 12 characters:

1. Scan the **Enter Setup** barcode.
2. Scan the **Set the Minimum Length** barcode.
3. Scan the numeric barcode "8" from the "Digit Barcodes" section in Appendix.
4. Scan the **Save** barcode from the "Save/Cancel Barcodes" section in Appendix.
5. Scan the **Set the Maximum Length** barcode.
6. Scan the numeric barcodes "1" and "2" from the "Digit Barcodes" section in Appendix.
7. Scan the **Save** barcode from the "Save/Cancel Barcodes" section in Appendix.
8. Scan the **Exit Setup** barcode.

Chapter 11 Prefix & Suffix

Introduction

A 1D barcode could contain digits, letters, symbols, etc. A 2D barcode could contain more data, such as Chinese characters and other multi-byte characters. However, in real applications, they do not and should not have all information we need, such as barcode type, data acquisition time and delimiter, in order to keep the barcodes short and flexible.

Prefix and suffix are how to fulfill the needs mentioned above. They can be added, removed and modified while the original barcode data remains intact.



Barcode processing procedure:

1. Edit data with Data Formatter
2. Append prefix/suffix
3. Pack data
4. Append terminating character

Global Settings

Enable/Disable All Prefixes/Suffixes

Disable All Prefixes/Suffixes: Transmit barcode data with no prefix/suffix.

Enable All Prefixes/Suffixes: Allow to append Code ID prefix, AIM ID prefix, custom prefix/suffix and terminating character to the barcode data before the transmission.



Disable All Prefixes/Suffixes



Enable All Prefixes/Suffixes

Prefix Sequence



Code ID+ Custom +AIM ID



Custom + Code ID + AIM ID

Custom Prefix

Enable/Disable Custom Prefix

If custom prefix is enabled, you are allowed to append to the data a user-defined prefix that cannot exceed 10 characters. For example, if the custom prefix is “AB” and the barcode data is “123”, the Host will receive “AB123”.



@CPRENA0

Disable Custom Prefix



@CPRENA1

Enable Custom Prefix

Set Custom Prefix

To set a custom prefix, scan the **Set Custom Prefix** barcode then the numeric barcodes corresponding to the hexadecimal value of a desired prefix then the **Save** barcode.

Note: A custom prefix cannot exceed 10 characters.



@CPRSET

Set Custom Prefix



Set the custom prefix to “CODE” (HEX: 0x43/0x4F/0x44/0x45):

1. Scan the **Enter Setup** barcode.
 2. Scan the **Set Custom Prefix** barcode.
 3. Scan the numeric barcodes “4”, “3”, “4”, “F”, “4”, “4”, “4” and “5” from the “Digit Barcodes” section in Appendix.
 4. Scan the **Save** barcode from the “Save/Cancel Barcodes” section in Appendix.
 5. Scan the **Enable Custom Prefix** barcode.
 6. Scan the **Exit Setup** barcode.
-

AIM ID Prefix

AIM (Automatic Identification Manufacturers) ID defines symbology identifier (For the details, see the “AIM ID Table” section in Appendix). If AIM ID prefix is enabled, the scanner will add the symbology identifier before the scanned data after decoding.



Disable AIM ID Prefix



Enable AIM ID Prefix



AIM ID is not user programmable.

Code ID Prefix

Code ID can also be used to identify barcode type. Unlike AIM ID, Code ID is user programmable. Code ID can only consist of one or two English letters.



@CIDENA0

Disable Code ID Prefix



@CIDENA1

Enable Code ID Prefix

Restore All Default Code IDs

For the information of default Code IDs, see the “Code ID Table” section in Appendix.



@CIDDEF

Restore All Default Code IDs

Modify Code ID

See the examples below to learn how to modify a Code ID and restore the default Code IDs of all symbologies.



Modify PDF417 Code ID to be “p” (HEX: 0x70):

1. Scan the **Enter Setup** barcode.
2. Scan the **Modify PDF417 Code ID** barcode.
3. Scan the numeric barcodes “7” and “0” from the “Digit Barcodes” section in Appendix.
4. Scan the **Save** barcode from the “Save/Cancel Barcodes” section in Appendix.
5. Scan the **Exit Setup** barcode.

Restore the default Code IDs of all symbologies:

1. Scan the **Enter Setup** barcode.
2. Scan the **Restore All Default Code IDs** barcode.
3. Scan the **Exit Setup** barcode.

1D symbologies:



@CID002

Modify Code 128 Code ID



@CID003

Modify GS1-128 Code ID



@CID004

Modify EAN-8 Code ID



@CID005

Modify EAN-13 Code ID



@CID006

Modify UPC-E Code ID



@CID007

Modify UPC-A Code ID



@CID008

Modify Interleaved 2 of 5 Code ID



@CID010

Modify ITF-6 Code ID



@CID013

Modify Code 39 Code ID



@CID017

Modify Code 93 Code ID

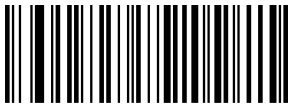

@CID020

Modify AIM 128 Code ID



@CID009

Modify ITF-14 Code ID



@CID011

Modify Matrix 2 of 5 Code ID



@CID015

Modify Codabar Code ID



@CID019

Modify China Post 25 Code ID



@CID021

Modify ISBT 128 Code ID



@CID023

Modify ISSN Code ID



@CID024

Modify ISBN Code ID



@CID025

Modify Industrial 25 Code ID



@CID026

Modify Standard 25 Code ID



@CID027

Modify Plessey Code ID



@CID028

Modify Code 11 Code ID



@CID029

Modify MSI-Plessey Code ID



@CID030

Modify GS1 Composite Code ID



@CID031

Modify GS1 Databar Code ID



@CID132

Modify Code 49 Code ID



@CID133

Modify Code 16K Code ID

2D symbologies:



@CID032

Modify PDF417 Code ID



@CID034

Modify Aztec Code ID



@CID036

Modify Maxicode Code ID



@CID041

Modify GM Code ID



@CID033

Modify QR Code ID



@CID035

Modify Data Matrix Code ID



@CID039

Modify Chinese Sensible Code ID



@CID043

Modify Micro QR Code ID



@CID050

DotCode



@CID042

Modify Micro PDF417 Code ID



@CID048

Modify Code One Code ID

Postal symbologies:



@CID096

Modify USPS Postnet Code ID



@CID098

Modify Royal Mail Code ID



@CID100

Modify KIX Post Code ID



@CID102

Modify Japan Post Code ID

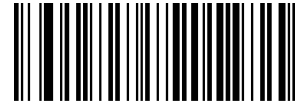

@CID097

Modify USPS Intelligent Mail Code ID



@CID099

Modify USPS Planet Code ID



@CID101

Modify Australian Postal Code ID

OCR:



@CID065

Modify Chinese ID Card OCR Code ID



@CID066

Modify Passport OCR Code ID



@CID068

Modify China Travel Permit OCR Code ID

Custom Suffix

Enable/Disable Custom Suffix

If custom suffix is enabled, you are allowed to append to the data a user-defined suffix that cannot exceed 10 characters. For example, if the custom suffix is “AB” and the barcode data is “123”, the Host will receive “123AB”.



Disable Custom Suffix



Enable Custom Suffix

Set Custom Suffix

To set a custom suffix, scan the **Set Custom Suffix** barcode then the numeric barcodes corresponding to the hexadecimal value of a desired suffix then the **Save** barcode.

Note: A custom suffix cannot exceed 10 characters.



Set Custom Suffix



Set the custom suffix to “CODE” (HEX: 0x43/0x4F/0x44/0x45):

1. Scan the **Enter Setup** barcode.
 2. Scan the **Set Custom Suffix** barcode.
 3. Scan the numeric barcodes “4”, “3”, “4”, “F”, “4”, “4”, “4” and “5” from the “Digit Barcodes” section in Appendix.
 4. Scan the **Save** barcode from the “Save/Cancel Barcodes” section in Appendix.
 5. Scan the **Enable Custom Suffix** barcode.
 6. Scan the **Exit Setup** barcode.
-

Terminating Character Suffix

Enable/Disable Terminating Character Suffix

A terminating character such as carriage return (CR) or carriage return/line feed pair (CRLF) can only be used to mark the end of data, which means nothing can be added after it.



Disable Terminating Character Suffix



Enable Terminating Character Suffix

Set Terminating Character Suffix

To set a terminating character suffix, scan the **Set Terminating Character Suffix** barcode then the numeric barcodes corresponding to the hexadecimal value of a desired terminating character then the **Save** barcode.

Note: A terminating character suffix cannot exceed 2 characters.



Set Terminating Character Suffix

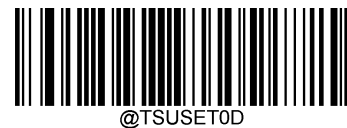

Set Terminating Character to CR (0x0D)

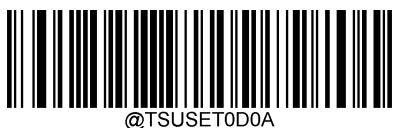

Set Terminating Character to CRLF (0x0D,0x0A)



Set the terminating character suffix to 0x0A:

1. Scan the **Enter Setup** barcode.
2. Scan the **Set Terminating Character Suffix** barcode.
3. Scan the numeric barcodes “0” and “A” from the “Digit Barcodes” section in Appendix.
4. Scan the **Save** barcode from the “Save/Cancel Barcodes” section in Appendix.
5. Scan the **Enable Terminating Character Suffix** barcode.
6. Scan the **Exit Setup** barcode.

Chapter 12 Programming Commands

Use of Programming Command

Besides the barcode programming method, the scanner can also be configured by serial commands (HEX) sent from the host device. **All commands must be entered in uppercase letters.**

Command Syntax

Prefix StorageType Tag SubTag {Data} [,SubTag {Data}] [:Tag SubTag {Data}] [...] Suffix

Prefix: "~<SOH>0000" (HEX: **7E 01 30 30 30 30**), 6 characters.

StorageType: "@" (HEX: **40**) or "#" (HEX: **23**), 1 character. "@" means permanent setting which will not be lost by removing power from the scanner or rebooting it; "#" means temporary setting which will be lost by removing power from the scanner or rebooting it.

Tag: A 3-character case-sensitive field that identifies the desired command group. For example, all USB HID Keyboard configuration settings are identified with a Tag of KBW.

SubTag: A 3-character case-sensitive field that identifies the desired parameter within the tag group. For example, the SubTag for the keyboard layout is CTY.

Data: The value for a feature or parameter setting, identified by the Tag and SubTag.

Suffix: ";<ETX>" (HEX: **3B 03**), 2 characters.

Multiple commands can be issued within one Prefix/Suffix sequence. For configuration commands, only the **Tag**, **SubTag**, and **Data** fields must be repeated for each command in sequence. If an additional command is to be applied to the same Tag, then the command is separated with a comma (,) and only the **SubTag** and **Data** fields of the additional commands are issued. If the additional command requires a different **Tag** field, the command is separated from previous command by a semicolon (;).

Query Commands

For query commands, the entry in the **Data** field in the syntax above is one of the following characters means:

* (HEX: **2A**) What is the scanner's current value for the setting(s).

& (HEX: **26**) What is the factory default value for the setting(s).

^ (HEX: **5E**) What is the range of possible values for the setting(s).

The value of the **StoreType** field in a query command can be either "@" (HEX: **40**) or "#" (HEX: **23**).

A query command with the **SubTag** field omitted means to query all the settings concerning a tag. For example, to query all the current settings about Code 11, you should enter **7E 01 30 30 30 30 40 43 31 31 2A 3B 03** (i.e. ~<SOH>0000@C11*; <ETX>).

Responses

Different from command sequence, the prefix of a response consists of the six characters of "<STX><SOH>0000" (HEX: **02 01 30 30 30 30**).

The scanner responds to serial commands with one of the following three responses:

<ACK> (HEX: **06**) Indicates a good command which has been processed.

<NAK> (HEX: **15**) Indicates a good configuration command with its **Data** field entry out of the allowable range for this Tag and SubTag combination (e.g. an entry for an inter-keystroke delay of 100 when the field will only allow 2 digits), or an invalid query command.

<ENQ> (HEX: **05**) Indicates an invalid Tag or SubTag command.

When responding, the scanner echoes back the command sequence with the status character above inserted directly before each of the punctuation marks (the comma or semicolon) in the command.

Examples

Example 1: Enable Code 11, set the minimum and maximum lengths to 12 and 22 respectively.

Enter: **7E 01 30 30 30 30 40 43 31 31 45 4E 41 31 2C 4D 49 4E 31 32 2C 4D 41 58 32 32 3B 03**
(~<SOH>0000@C11ENA1,MIN12,MAX22;<ETX>)

Response: **02 01 30 30 30 30 40 43 31 31 45 4E 41 31 06 2C 4D 49 4E 31 32 06 2C 4D 41 58 32 32 06 3B 03**
(<STX><SOH>0000@C11ENA1<ACK>,MIN12<ACK>,MAX22<ACK>;<ETX>)

Example 2: Query the current minimum and maximum lengths of Code 11.

Enter: **7E 01 30 30 30 30 40 43 31 31 4D 49 4E 2A 2C 4D 41 58 2A 3B 03**
(~<SOH>0000@C11MIN*,MAX*;<ETX>)

Response: **02 01 30 30 30 30 40 43 31 31 4D 49 4E 31 32 06 2C 4D 41 58 32 32 06 3B 03**
(<STX><SOH>0000@C11MIN12<ACK>,MAX22<ACK>;<ETX>)



Note: If you need to change device parameters in real-time via the host, it is recommended to use the temporary setting with **StorageType set to “#”**. The permanent setting, with **StorageType set to “@”**, involves erasing and writing to the flash memory, which may affect the lifespan of the device's flash memory.

Chapter 13 Batch Programming

Introduction

Batch programming enables users to integrate a batch of commands into a single batch barcode.

Listed below are batch programming rules:

1. Command format: Command + Parameter Value.
2. Each command is terminated by a semicolon (;). Note that there is no space between a command and its terminator semicolon.
3. Use the barcode generator software to generate a 2D batch barcode.

Example: Create a batch barcode for **Illumination Always On, Sense Mode, Decode Session Timeout = 2s**:

1. Input the commands:

```
@ILLSCN2;SCNMOD2;ORTSET2000;
```

2. Generate a batch barcode.

When setting up a scanner with the above configuration, scan the **Enable Batch Barcode** barcode and then the batch barcode generated.



@BATCHS

Enable Batch Barcode

Create a Batch Command

A batch command may contain a number of individual commands each of which is terminated by a semicolon (;).

For more information, refer to the “Use of Programming Command” section in Chapter 3.

Create a Batch Barcode

Batch barcodes can be produced in the format of PDF417, QR Code or Data Matrix.

Example: Create a batch barcode for **Illumination Always On, Sense Mode, Decode Session Timeout = 2s**:

1. Input the following commands:

```
@ILLSCN2;SCNMOD2;ORTSET2000;
```

2. Generate a PDF417 batch barcode.



Use Batch Barcode

To put a batch barcode into use, scan the following barcodes. (Use the example above.)

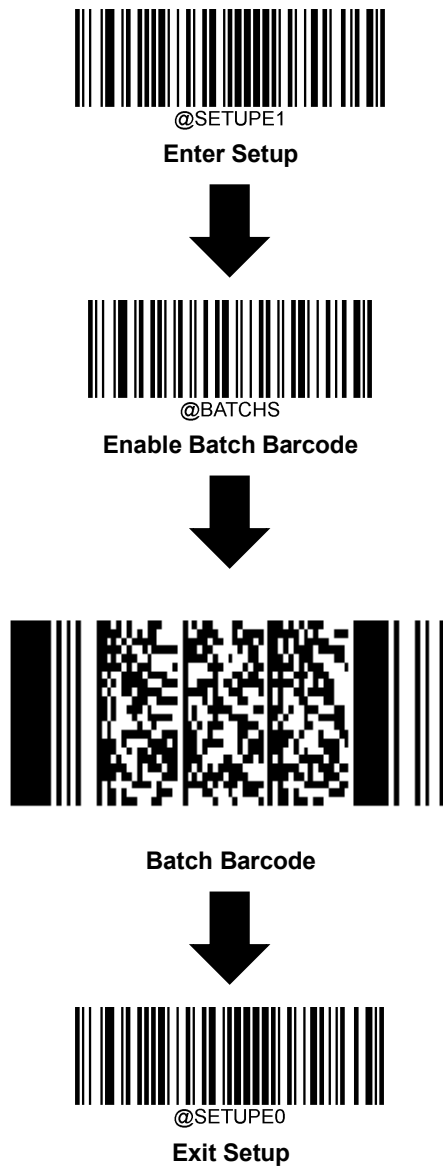

Chapter 14 JavaScript Development Guide

Introduction

This chapter introduces the core operation of JavaScript in the FM600 device. It covers key development aspects such as variable control, flow statements, and string processing, helping users quickly build barcode data processing logic.

Function

Core Functions

Below are the core functions available for scripting in the FM600 device:

| | |
|--------------|--|
| Function | int get_codes() |
| Description | Retrieves the total number of codewords, supporting both single-barcode and multi-barcode scenarios. |
| Parameters | None |
| Return Value | Integer, representing the number of codewords. |
| Function | string get_decMsg(int n) |
| Description | Retrieves the nth codeword from the list of all codewords. |
| Parameters | n (integer, range: 0 to N); the index of the codeword in the list of all codewords. |
| Return Value | String, representing the nth codeword |
| Function | int get_msgLength(int n) |
| Description | Retrieves the length of the nth codeword from the list of all codewords. |
| Parameters | n (integer, range: 0 to N); the index of the codeword in the list of all codewords. |
| Return Value | Integer, representing the length of the nth codeword. |

| | |
|--------------|---|
| Function | void set_codes (int n) |
| Description | Sets or modifies the total number of codewords |
| Parameters | n (integer); the total number of codewords. |
| Return Value | None |
| Function | void set_decMsg (int n,string newMess,int length) |
| Description | Sets, edits, or modifies the nth codeword |
| Parameters | n (integer): The index of the codeword in the list of all codewords. newMess (string): The new content of the codeword. length (integer): The length of the codeword. |
| Return Value | None |

Data Processing Functions

String Extraction: ``substring(start, end)`` / ``substr(start, length)``

String Replacement: ``replace(oldStr, newStr)``

String Conversion: ``toLowerCase()`` / ``toUpperCase()``

String Concatenation: ``concat(str1, str2, ...)``

String Reversal: ``split("").reverse().join("")``

Basic Programming Guidelines

Variable Management

// Variable declaration example

`var codeCount = get_codes();` *// Automatically inferred as an integer type*

`var message = get_decMsg(0);` *// Automatically inferred as a string type*

Conditional Judgment

```
var msgLen = get_msgLength(0);

if (msgLen <= 10) {

    var result = "short";

} else {

    var result = "long";

}
```

Loop Control

```
for (var i = 0; i < get_codes(); i++) {

    var currentMsg = get_decMsg(i);

    // Execute specific business logic

}
```

Advanced String Processing

Content Operations

// Character positioning and substring extraction

```
var msg = get_decMsg(0);

var index = msg.indexOf('123');

var subMsg = msg.substr(index + 1);

// Regular expression matching
```

```
var searchResult = msg.search(/abc/);
```

Format Conversion

```
// Case conversion
```

```
var upperMsg = msg.toLocaleUpperCase();
```

```
var lowerMsg = msg.toLowerCase();
```

```
// Type conversion
```

```
var numericValue = parseInt(msg);
```

```
var stringValue = numericValue.toString();
```

System Configuration Methods

Scanner Settings

```
// Set default parameters
```

```
function initScannerConfig() {
```

```
    set_codes(200); // Initialize codeword library capacity
```

```
    set_decMsg(0, "DEFAULT_CODE", 10); // Set default codeword
```

```
}
```

```
// Dynamic configuration update
```

```
function updateConfig() {
```

```
    var currentCount = get_codes();
```

```
    for (var i = 0; i < currentCount; i++) {
```

```
        var msg = get_decMsg(i);
```

```
    if (msg.startsWith("TEMP")) {  
        set_decMsg(i, msg.replace("TEMP", "ACTIVE"), msg.length);  
    }  
}  
}
```

Security and Exception Handling

Parameter Validation

```
function validateInput(n) {  
    if (typeof n !== 'number' || n < 0 || n >= get_codes()) {  
        return -1; // Return error code  
    }  
    return 0; // Return 0 if validation passes  
}
```

// Example call

```
var validationResult = validateInput(100);  
if (validationResult !== 0) {  
    var errorMsg = "Invalid parameter";  
    // Execute error handling logic  
}
```

Error Handling Mechanism

```
var errorStatus = 0;
```

```
try {  
  
    var sensitiveMsg = get_decMsg(100); // Index out of range  
  
} catch (error) {  
  
    errorStatus = 1; // Set error status code  
  
    set_decMsg(999, "ERROR_CODE", 10); // Record error code  
  
}
```

```
// Perform follow-up operations based on error status
```

```
if (errorStatus === 1) {  
  
    // Handle error scenario  
  
}
```

Configuration

Use the Nset to configure the JavaScript

1. Go to **Advanced Setup**
2. Select **Data Editing**
3. In **Data Editing**, Select "**Advanced Mode**"
4. Navigate to **JavaScript** and write the script
5. Save the settings to the device

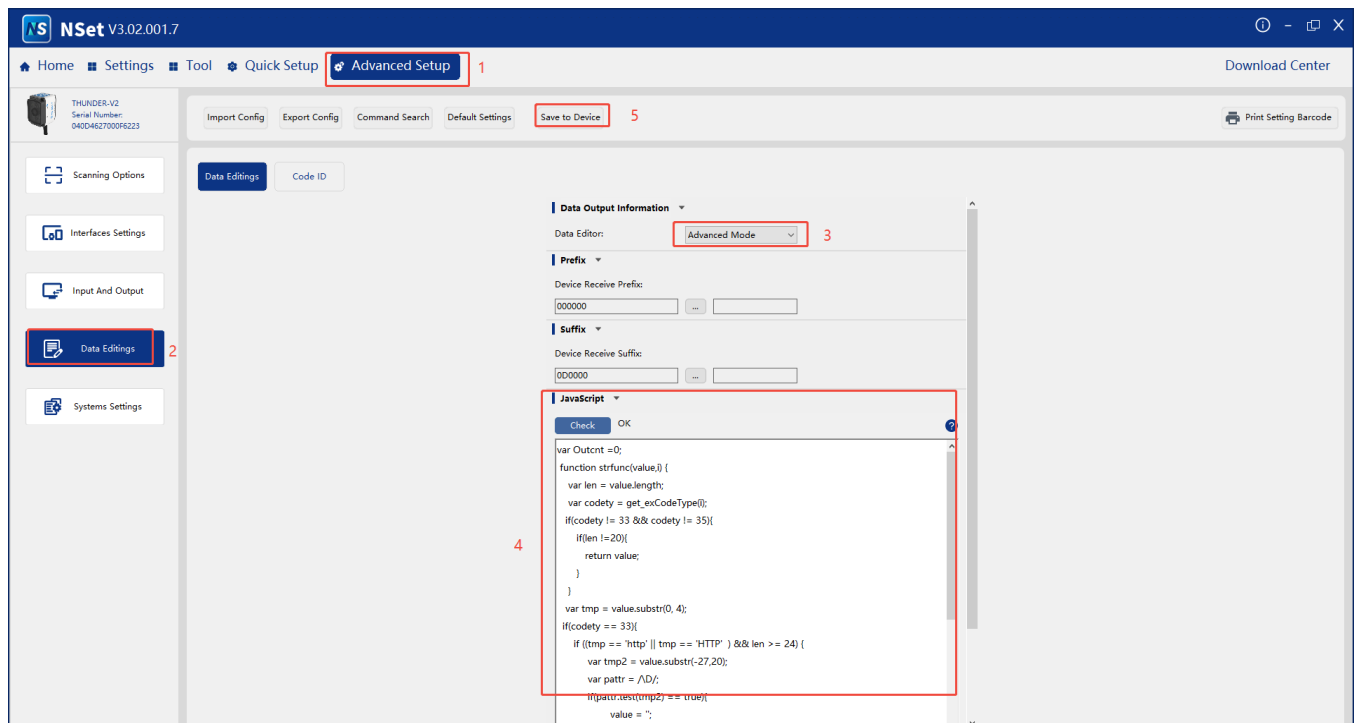

Appendix

Digit Barcodes

0~9



@DIGIT0

0



@DIGIT2

2



@DIGIT4

4



@DIGIT1

1



@DIGIT3

3



@DIGIT5

5



@DIGIT6

6



@DIGIT7

7



@DIGIT8

8



@DIGIT9

9

A~F



@DIGITA

A



@DIGITB

B



@DIGITC

C



@DIGITD

D



@DIGITE

E



@DIGITF

F

Save/Cancel Barcodes

After reading numeric barcode(s), you need to scan the **Save** barcode to save the data. If you scan the wrong digit(s), you can either scan the **Cancel** barcode and then start the configuration all over again, or scan the **Delete the Last Digit** barcode and then the correct digit, or scan the **Delete All Digits** barcode and then the digits you want.

For instance, after reading the **Maximum Length** barcode and numeric barcodes “1”, “2” and “3”, you scan:

- ✧ **Delete the Last Digit:** The last digit “3” will be removed.
- ✧ **Delete All Digits:** All digits “123” will be removed.
- ✧ **Cancel:** The maximum length configuration will be cancelled. And the scanner is still in the setup mode.



@DIGSAV

Save



@DIGCAN

Cancel



@DIGDEL

Delete the Last Digit



@DIGDAL

Delete All Digits

Factory Defaults Table (V1.00.0)

| Parameter | Factory Default | Remark |
|-----------------------------------|--------------------------------------|----------------------------|
| Setup Settings | | |
| Barcode Programming | Disabled (Exit Setup) | |
| Programming Barcode Data | Do not transmit | |
| Communication Settings | | |
| Adaptive Wired Communication | On | |
| Default Interface | USB CDC | |
| RS-232 Interface | | |
| Baud Rate | 9600 | |
| Parity Check | None | |
| Data Bits | 8 | |
| Stop Bits | 1 | |
| USB Interface | | |
| USB Country Keyboard | US keyboard | USB HID Keyboard |
| Beep on Unknown Character | Off | USB HID Keyboard |
| Emulate ALT+Keypad | Off | USB HID Keyboard |
| Code Page | Code Page 1252 (West European Latin) | USB HID Keyboard |
| Unicode Encoding | Off | USB HID Keyboard |
| Emulate Keypad with Leading Zero | On | USB HID Keyboard |
| Function Key Mapping | Disable | USB HID Keyboard |
| Inter-Keystroke Delay | No Delay | USB HID Keyboard |
| Caps Lock | Caps Lock OFF, non-Japanese Keyboard | USB HID Keyboard |
| Convert Case | No Case Conversion | USB HID Keyboard |
| Emulate Numeric Keypad 1 | Off | USB HID Keyboard |
| Emulate Numeric Keypad 2 | Off | USB HID Keyboard |
| Fast Mode | Off | USB HID Keyboard |
| Polling Rate | 4ms | USB HID Keyboard |
| Basic Settings | | |
| Scan Mode | Level Mode | |
| Decode Session Timeout | 3000ms | 1-3,600,000ms; 0: Infinite |
| Types of Triggering | High Level Triggering | |
| Enter the Detection/Reading State | Enter the Detection | |
| Image Stabilization Timeout | 500ms | 1-3000ms |

| | | |
|-------------------------------------|----------------------|---------------|
| Trigger Selection | IR Proximity Trigger | |
| Image Change Trigger Sensitivity | 5 | |
| Scanning Interval (Continuous Mode) | 500ms | |
| Read Timeout | Disabled , 1500ms | 1-3,600,000ms |
| Reread Timeout Reset | Off | |
| Good Read Delay | Disabled, 500ms | 1-3,600,000ms |
| Scanning Preference | Normal Mode | |
| Security Level | Security Level 0 | |
| Decode Area | Whole Area Decoding | |
| Image Flipping | Do Not Flip | |
| Bad Read Message | Do not Send | |
| Bad Read Message | NG | |
| Polarity of Good Read Signal | Low Level Output | |
| Good Read Indicator Duration | 500ms | |
| Good Read Indicator Delay | 0 | |
| Polarity of Bad Read Signal | Low Level Output | |
| Bad Read Indicator Duration | 500ms | |
| Bad Read Indicator Delay | 0 | |
| Trigger Commands | Enabled | |
| Start Scanning Command | <SOH> T <EOT> | |
| Stop Scanning Command | <SOH> P <EOT> | |
| Power On LED Indicator | On | |
| Illumination | On | |
| Aiming | On | |
| Good Read LED | On | |
| Good Read LED Duration | 20ms | |
| Power On Beep | On | |
| Good Read Beep | On | |
| Good Read Beep Duration | Medium (80ms) | |
| Good Read Beep Frequency | Medium (2730Hz) | |
| Good Read Beep Volume | Loud | |
| Auto Sleep | Disabled | |
| Time Period from Idle to Sleep | | |
| Symbologies | | |
| Global Settings | | |

| | | |
|--|---|--|
| 1D Inverse Code | Regular 1D Code Only | |
| Surround GS1 AI's with Parentheses | Do Not Surround GS1 AI's with Parentheses | |
| Code 128 | | |
| Code 128 | Enabled | |
| Maximum Length | 127 | |
| Minimum Length | 1 | |
| EAN-8 | | |
| EAN-8 | Enabled | |
| Check Character | Transmit the Check Character | |
| 2-Digit Add-On Code | Disabled | |
| 5-Digit Add-On Code | Disabled | |
| Add-On Code | Not Required | |
| EAN-13 | | |
| EAN-13 | Enabled | |
| Check Character | Transmit the Check Character | |
| 2-Digit Add-On Code | Disabled | |
| 5-Digit Add-On Code | Disabled | |
| Add-On Code | Not Required | |
| UPC-E | | |
| UPC-E0 | Enabled | |
| UPC-E1 | Disabled | |
| Check Character | Transmit the Check Character | |
| 2-Digit Add-On Code | Disabled | |
| 5-Digit Add-On Code | Disabled | |
| Add-On Code | Not Required | |
| Transmit Preamble Character | System Character | |
| UPC-A | | |
| UPC-A | Enabled | |
| Check Character | Transmit the Check Character | |
| 2-Digit Add-On Code | Disabled | |
| 5-Digit Add-On Code | Disabled | |
| Add-On Code | Not Required | |
| Transmit Preamble Character | Do Not Transmit | |
| Coupon | | |
| UPC-A/EAN-13 with Extended Coupon Code | Disabled | |

| | | |
|----------------------------------|-----------------|----------------|
| Coupon GS1 DataBar Output | Disabled | |
| Interleaved 2 of 5 | | |
| Interleaved 2 of 5 | Enabled | |
| Maximum Length | 127 | |
| Minimum Length | 1 | No less than 4 |
| Check Character Verification | Disabled | |
| Febraban | | |
| Febraban | Disabled | |
| Transmit Delay per Character | Disabled | |
| | 70ms | |
| Transmit Delay per 12 Characters | Disabled | |
| | 500ms | |
| ITF-14 | | |
| ITF-14 | Disabled | |
| ITF-6 | | |
| ITF-6 | Disabled | |
| Matrix 2 of 5 | | |
| Matrix 2 of 5 | Enabled | |
| Maximum Length | 127 | |
| Minimum Length | 1 | No less than 1 |
| Check Character Verification | Disabled | |
| Code 39 | | |
| Code 39 | Enabled | |
| Maximum Length | 127 | |
| Minimum Length | 1 | |
| Check Character Verification | Disabled | |
| Start/Stop Character | Do not transmit | |
| Code 39 Full ASCII | Enabled | |
| Code 32 Pharmaceutical (PARAF) | Disabled | |
| Code 32 Prefix | Disabled | |
| Code 32 Start/Stop Character | Do not transmit | |
| Code 32 Check Character | Do not transmit | |
| Codabar | | |
| Codabar | Enabled | |
| Maximum Length | 127 | |

| | | |
|------------------------------|----------------------------|----------------|
| Minimum Length | 1 | |
| Check Character Verification | Disabled | |
| Start/Stop Character | Do not transmit | |
| | ABCD/ABCD | |
| Code 93 | | |
| Code 93 | Enabled | |
| Maximum Length | 127 | |
| Minimum Length | 1 | No less than 1 |
| Check Character Verification | Enabled | |
| China Post 25 | | |
| China Post 25 | Disabled | |
| Maximum Length | 127 | |
| Minimum Length | 1 | |
| Check Character Verification | Disabled | |
| GS1-128 (UCC/EAN-128) | | |
| GS1-128 | Enabled | |
| Maximum Length | 127 | |
| Minimum Length | 1 | |
| Check Character Verification | | |
| GS1 Databar | | |
| GS1 Databar | Enabled | |
| Application Identifier "01" | Transmit | |
| EAN-UCC Composite | | |
| GS1 Composite | Disabled | |
| UPC/EAN Composite | Disabled | |
| Code 11 | | |
| Code 11 | Disabled | |
| Maximum Length | 127 | |
| Minimum Length | 1 | No less than 1 |
| Check Character Verification | One Check Character, MOD11 | |
| Check Character | Transmit | |
| ISBN | | |
| ISBN | Enabled | |
| Set ISBN Format | ISBN-13 | |
| ISSN | | |

| | | |
|------------------------------|----------------------------|----------------|
| ISSN | Disabled | |
| Industrial 25 | | |
| Industrial 25 | Disabled | |
| Maximum Length | 127 | |
| Minimum Length | 1 | No less than 1 |
| Check Character Verification | Disabled | |
| Standard 25 | | |
| Standard 25 | Enabled | |
| Maximum Length | 127 | |
| Minimum Length | 1 | No less than 1 |
| Check Character Verification | Disabled | |
| Plessey | | |
| Plessey | Enabled | |
| Maximum Length | 127 | |
| Minimum Length | 1 | No less than 1 |
| Check Character Verification | Disabled | |
| MSI-Plessey | | |
| MSI-Plessey | Enabled | |
| Maximum Length | 127 | |
| Minimum Length | 1 | No less than 1 |
| Check Character Verification | One Check Character, MOD10 | |
| Check Character | Do Not Transmit | |
| AIM 128 | | |
| AIM 128 | Enabled | |
| Maximum Length | 127 | |
| Minimum Length | 1 | |
| ISBT 128 | | |
| ISBT 128 | Disabled | |
| Code 49 | | |
| Code 49 | Disabled | |
| Maximum Length | 80 | |
| Minimum Length | 1 | |
| Code 16K | | |
| Code 16K | Disabled | |
| Maximum Length | 80 | |

| | | |
|---|-------------------------------------|------|
| Minimum Length | 1 | |
| Pharmacode | | |
| Pharmacode | Disable | |
| One-Track | Enable | |
| Pharmacode One-Track Decoding Direction | Left to Right | |
| Minimum Number of Pharmacode One-Track | 9 | 2~16 |
| Maximum Number of Pharmacode One-Track | 16 | |
| Pharmacode One-Track Inverse | Regular | |
| Pharmacode One-Track Quiet Zone | 9 | 1~20 |
| Pharmacode One-Track Output Format | Normal Format | |
| Two-Track | Enable | |
| Pharmacode Two-Track Decoding Direction | Left to Right | |
| Minimum Number of Pharmacode Two -Track | 9 | 2~16 |
| Maximum Number of Pharmacode Two -Track | 16 | |
| Pharmacode Two -Track Inverse | Regular | |
| Pharmacode Two -Track Quiet Zone | 9 | 1~20 |
| Pharmacode Two -Track Output Format | Normal Format | |
| PDF417 | | |
| PDF417 | Enabled | |
| Maximum Length | 2710 | |
| Minimum Length | 1 | |
| PDF417 Inverse | Decode Regular PDF417 Barcodes Only | |
| Character Encoding | Default Character Encoding | |
| PDF417 ECI Output | Enabled | |
| Micro PDF417 | | |
| Micro PDF417 | Disabled | |
| Maximum Length | 366 | |
| Minimum Length | 1 | |
| QR Code | | |
| QR Code | Enabled | |
| Maximum Length | 7089 | |
| Minimum Length | 1 | |
| QR Inverse | Decode Regular QR Barcodes Only | |
| Character Encoding | Default Character Encoding | |
| QR ECI Output | Enabled | |

| | | |
|-------------------------------|---|--|
| URL QR | | |
| Custom URL QR | | |
| Micro QR Code | | |
| Micro QR | Enabled | |
| Maximum Length | 35 | |
| Minimum Length | 1 | |
| Aztec | | |
| Aztec Code | Disabled | |
| Maximum Length | 3832 | |
| Minimum Length | 1 | |
| Aztec Inverse | Decode Regular Aztec Barcodes Only | |
| Character Encoding | Default Character Encoding | |
| Aztec ECI Output | Enabled | |
| Data Matrix | | |
| Data Matrix | Enabled | |
| Maximum Length | 3116 | |
| Minimum Length | 1 | |
| Rectangular Barcode | Enabled | |
| Data Matrix Inverse | Decode Regular Data Matrix Barcodes Only | |
| Character Encoding | Default Character Encoding | |
| Data Matrix ECI Output | Enabled | |
| Maxicode | | |
| Maxicode | | |
| Maxicode | Disabled | |
| Maximum Length | 150 | |
| Minimum Length | 1 | |
| Chinese Sensible Code | | |
| Chinese Sensible Code | Disabled | |
| Maximum Length | 7827 | |
| Minimum Length | 1 | |
| Chinese Sensible Code Inverse | Decode Regular Chinese Sensible Barcodes Only | |
| GM Code | | |
| GM | Disabled | |
| Maximum Length | 2751 | |

| | | |
|--------------------------------|-------------------------|--|
| Minimum Length | 1 | |
| Code One | | |
| Code One | Disabled | |
| Maximum Length | 3550 | |
| Minimum Length | 1 | |
| DotCode | | |
| DotCode | Disabled | |
| Maximum Length | | |
| Minimum Length | | |
| USPS Postnet | | |
| USPS Postnet | Disabled | |
| Check Character | Transmit | |
| USPS Intelligent Mail | | |
| USPS Intelligent Mail | Disabled | |
| Royal Mail | | |
| Royal Mail | Disabled | |
| USPS Planet | | |
| USPS Planet | Disabled | |
| Check Character | Transmit | |
| KIX Post | | |
| KIX Post | Disabled | |
| Australian Postal | | |
| Australian Postal | Disabled | |
| Japan Post | | |
| Japan Post | Disabled | |
| Chinese ID Card OCR | | |
| Chinese ID Card OCR | Disabled | |
| Passport OCR | | |
| Passport OCR | Disabled | |
| China Travel Permit OCR | | |
| China Travel Permit OCR | Disabled | |
| Prefix & Suffix | | |
| All Prefixes/Suffixes | Disabled | |
| Prefix Sequence | Code ID+ Custom +AIM ID | |
| Custom Prefix | Disabled | |

| | | |
|------------------------------|------------------|--|
| AIM ID Prefix | Disabled | |
| Code ID Prefix | Disabled | |
| Custom Suffix | Disabled | |
| Terminating Character Suffix | Enabled (Return) | |

AIM ID Table (V1.00.0)

| Symbology | AIM ID | Possible AIM ID Modifiers (m) |
|-----------------------|--------|-------------------------------|
| Code 128 |]C0 | |
| GS1-128 (UCC/EAN-128) |]C1 | |
| EAN-8 |]E4 | |
| EAN-8 with Addon |]E3 | |
| EAN-13 |]E0 | |
| EAN-13 with Addon |]E3 | |
| UPC-E |]E0 | |
| UPC-E with Addon |]E3 | |
| UPC-A |]E0 | |
| UPC-A with Addon |]E3 | |
| Interleaved 2 of 5 |]Im | 0, 1, 3 |
| ITF-14 |]Im | 1, 3 |
| ITF-6 |]Im | 1, 3 |
| Matrix 2 of 5 |]X0 | |
| Code 39 |]Am | 0, 1, 3, 4, 5, 7 |
| Codabar |]Fm | 0, 2, 4 |
| Code 93 |]G0 | |
| China Post 25 |]X0 | |
| AIM 128 |]C2 | |
| ISBT 128 |]C4 | |
| ISSN |]X0 | |
| ISBN |]X0 | |
| Industrial 25 |]S0 | |
| Standard 25 |]R0 | |
| Plessey |]P0 | |
| Code 11 |]Hm | 0, 1, 3 |
| MSI Plessey |]Mm | 0, 1 |
| GS1 Composite |]em | 0-3 |
| GS1 Databar(RSS) |]e0 | |
| Code 49 |]T0 | |
| Code 16K |]K0 | |
| Pharmacode |]X0 | |

| | | |
|-----------------------------|-----|----------|
| PDF417 |]Lm | 0-2 |
| QR Code |]Qm | 0-6 |
| Aztec |]zm | 0-9, A-C |
| Data Matrix |]dm | 0-6 |
| Maxicode |]Um | 0-3 |
| 汉信码 (Chinese Sensible Code) |]X0 | |
| GM |]gm | (0~9) |
| Micro PDF417 |]L0 | |
| Micro QR |]Q1 | |
| Code One |]X0 | |
| DotCode |]Jm | 0~5 |
| USPS Postnet |]X0 | |
| USPS Intelligent Mail |]X0 | |
| Royal Mail |]X0 | |
| USPS Planet |]X0 | |
| KIX Post |]X0 | |
| Australian Postal |]X0 | |
| Japan Post |]X0 | |
| Passport OCR |]o2 | |
| Chinese ID Card |]o2 | |
| China Travel Permit OCR |]o2 | |

Code ID Table (V1.00.0)

| Symbology | Code ID |
|-----------------------|---------|
| Code 128 | j |
| GS1-128 (UCC/EAN-128) | j |
| EAN-8 | d |
| EAN-13 | d |
| UPC-E | c |
| UPC-A | c |
| Interleaved 2 of 5 | e |
| ITF-14 | e |
| ITF-6 | e |
| Matrix 2 of 5 | v |
| Code 39 | b |
| Codabar | a |
| Code 93 | i |
| China Post 25 | X |
| AIM 128 | X |
| ISBT 128 | X |
| ISSN | g |
| ISBN | B |
| Industrial 25 | l |
| Standard 25 | f |
| Plessey | n |
| Code 11 | H |
| MSI Plessey | m |
| GS1 Composite | y |
| GS1 Databar (RSS) | R |
| Code 49 | X |
| Code 16K | X |
| Pharmacode | X |
| PDF417 | r |
| QR Code | s |
| Aztec | z |
| Data Matrix | u |

| | |
|-------------------------|---|
| MaxiCode | x |
| Chinese Sensible Code | h |
| GM Code | x |
| Micro PDF417 | R |
| Micro QR | X |
| Code One | X |
| DotCode | X |
| USPS Postnet | P |
| USPS Intelligent Mail | M |
| Royal Mail | x |
| USPS Planet | L |
| KIX Post | K |
| Australian Postal | A |
| Japan Post | J |
| Passport OCR | O |
| Chinese ID Card | S |
| China Travel Permit OCR | S |

Symbology ID Number (V1.00.0)

| Symbology | ID Number |
|-----------------------|-----------|
| Code 128 | 002 |
| GS1-128 (UCC/EAN-128) | 003 |
| EAN-8 | 004 |
| EAN-13 | 005 |
| UPC-E | 006 |
| UPC-A | 007 |
| Interleaved 2 OF 5 | 008 |
| ITF-14 | 009 |
| ITF-6 | 010 |
| Matrix 2 of 5 | 011 |
| Code 39 | 013 |
| Codabar | 015 |
| Code 93 | 017 |
| China Post 25 | 019 |
| AIM 128 | 020 |
| ISBT 128 | 021 |
| ISSN | 023 |
| ISBN | 024 |
| Industrial25 | 025 |
| Standard25 | 026 |
| Plessey | 027 |
| Code11 | 028 |
| MSI-Plessey | 029 |
| GS1 Composite | 030 |
| GS1 Databar (RSS) | 031 |
| PDF417 | 032 |
| QR Code | 033 |
| Aztec | 034 |
| Data Matrix | 035 |
| Maxicode | 036 |
| Chinese Sensible Code | 039 |
| GM Code | 040 |

| | |
|-------------------------|-----|
| Micro PDF417 | 042 |
| Micro QR | 043 |
| Code One | 048 |
| DotCode | 050 |
| Chinese ID Card | 065 |
| Passport OCR | 066 |
| China Travel Permit OCR | 068 |
| USPS Postnet | 096 |
| USPS Intelligent Mail | 097 |
| Royal Mail | 098 |
| USPS Planet | 099 |
| KIX Post | 100 |
| Australian Postal | 101 |
| Japan Post | 102 |
| Code 49 | 132 |
| Code 16K | 133 |

ASCII Table

| Hex | Dec | Char |
|-----|-----|-------------------------------|
| 00 | 0 | NUL (Null char.) |
| 01 | 1 | SOH (Start of Header) |
| 02 | 2 | STX (Start of Text) |
| 03 | 3 | ETX (End of Text) |
| 04 | 4 | EOT (End of Transmission) |
| 05 | 5 | ENQ (Enquiry) |
| 06 | 6 | ACK (Acknowledgment) |
| 07 | 7 | BEL (Bell) |
| 08 | 8 | BS (Backspace) |
| 09 | 9 | HT (Horizontal Tab) |
| 0a | 10 | LF (Line Feed) |
| 0b | 11 | VT (Vertical Tab) |
| 0c | 12 | FF (Form Feed) |
| 0d | 13 | CR (Carriage Return) |
| 0e | 14 | SO (Shift Out) |
| 0f | 15 | SI (Shift In) |
| 10 | 16 | DLE (Data Link Escape) |
| 11 | 17 | DC1 (XON) (Device Control 1) |
| 12 | 18 | DC2 (Device Control 2) |
| 13 | 19 | DC3 (XOFF) (Device Control 3) |
| 14 | 20 | DC4 (Device Control 4) |
| 15 | 21 | NAK (Negative Acknowledgment) |
| 16 | 22 | SYN (Synchronous Idle) |
| 17 | 23 | ETB (End of Trans. Block) |
| 18 | 24 | CAN (Cancel) |
| 19 | 25 | EM (End of Medium) |
| 1a | 26 | SUB (Substitute) |
| 1b | 27 | ESC (Escape) |
| 1c | 28 | FS (File Separator) |
| 1d | 29 | GS (Group Separator) |

| Hex | Dec | Char |
|-----|-----|--------------------------------|
| 1e | 30 | RS (Request to Send) |
| 1f | 31 | US (Unit Separator) |
| 20 | 32 | SP (Space) |
| 21 | 33 | ! (Exclamation Mark) |
| 22 | 34 | " (Double Quote) |
| 23 | 35 | # (Number Sign) |
| 24 | 36 | \$ (Dollar Sign) |
| 25 | 37 | % (Percent) |
| 26 | 38 | & (Ampersand) |
| 27 | 39 | ` (Single Quote) |
| 28 | 40 | ((Left/ Opening Parenthesis) |
| 29 | 41 |) (Right/ Closing Parenthesis) |
| 2a | 42 | * (Asterisk) |
| 2b | 43 | + (Plus) |
| 2c | 44 | , (Comma) |
| 2d | 45 | - (Minus/ Dash) |
| 2e | 46 | . (Dot) |
| 2f | 47 | / (Forward Slash) |
| 30 | 48 | 0 |
| 31 | 49 | 1 |
| 32 | 50 | 2 |
| 33 | 51 | 3 |
| 34 | 52 | 4 |
| 35 | 53 | 5 |
| 36 | 54 | 6 |
| 37 | 55 | 7 |
| 38 | 56 | 8 |
| 39 | 57 | 9 |
| 3a | 58 | : (Colon) |
| 3b | 59 | ; (Semi-colon) |
| 3c | 60 | < (Less Than) |
| 3d | 61 | = (Equal Sign) |

| Hex | Dec | Char |
|-----|-----|----------------------------|
| 3e | 62 | > (Greater Than) |
| 3f | 63 | ? (Question Mark) |
| 40 | 64 | @ (AT Symbol) |
| 41 | 65 | A |
| 42 | 66 | B |
| 43 | 67 | C |
| 44 | 68 | D |
| 45 | 69 | E |
| 46 | 70 | F |
| 47 | 71 | G |
| 48 | 72 | H |
| 49 | 73 | I |
| 4a | 74 | J |
| 4b | 75 | K |
| 4c | 76 | L |
| 4d | 77 | M |
| 4e | 78 | N |
| 4f | 79 | O |
| 50 | 80 | P |
| 51 | 81 | Q |
| 52 | 82 | R |
| 53 | 83 | S |
| 54 | 84 | T |
| 55 | 85 | U |
| 56 | 86 | V |
| 57 | 87 | W |
| 58 | 88 | X |
| 59 | 89 | Y |
| 5a | 90 | Z |
| 5b | 91 | [(Left/ Opening Bracket) |
| 5c | 92 | \ (Back Slash) |
| 5d | 93 |] (Right/ Closing Bracket) |

| Hex | Dec | Char |
|-----|-----|--------------------------|
| 5e | 94 | ^ (Caret/ Circumflex) |
| 5f | 95 | _ (Underscore) |
| 60 | 96 | ' (Grave Accent) |
| 61 | 97 | a |
| 62 | 98 | b |
| 63 | 99 | c |
| 64 | 100 | d |
| 65 | 101 | e |
| 66 | 102 | f |
| 67 | 103 | g |
| 68 | 104 | h |
| 69 | 105 | i |
| 6a | 106 | j |
| 6b | 107 | k |
| 6c | 108 | l |
| 6d | 109 | m |
| 6e | 110 | n |
| 6f | 111 | o |
| 70 | 112 | p |
| 71 | 113 | q |
| 72 | 114 | r |
| 73 | 115 | s |
| 74 | 116 | t |
| 75 | 117 | u |
| 76 | 118 | v |
| 77 | 119 | w |
| 78 | 120 | x |
| 79 | 121 | y |
| 7a | 122 | z |
| 7b | 123 | { (Left/ Opening Brace) |
| 7c | 124 | (Vertical Bar) |
| 7d | 125 | } (Right/ Closing Brace) |
| 7e | 126 | ~ (Tilde) |
| 7f | 127 | DEL (Delete) |

Keyboard Key References

| | | | | | | | | | | | | | | | | | | | | |
|----|----|----|----|----|----|----|----|----|----|----|----|----|----|----|----|----|----|----|----|----|
| 6E | 70 | 71 | 72 | 73 | 74 | 75 | 76 | 77 | 78 | 79 | 7A | 7B | 7C | 7D | 7E | • | • | • | | |
| 01 | 02 | 03 | 04 | 05 | 06 | 07 | 08 | 09 | 0A | 0B | 0C | 0D | 0F | 4B | 50 | 55 | 5A | 5F | 64 | 69 |
| 10 | 11 | 12 | 13 | 14 | 15 | 16 | 17 | 18 | 19 | 1A | 1B | 1C | 1D | 4C | 51 | 56 | 5B | 60 | 65 | 6A |
| 1E | 1F | 20 | 21 | 22 | 23 | 24 | 25 | 26 | 27 | 28 | 29 | 2B | | | | 5C | 61 | 66 | | |
| 2C | 2E | 2F | 30 | 31 | 32 | 33 | 34 | 35 | 36 | 37 | 39 | | | 53 | | | 5D | 62 | 67 | 6C |
| 3A | 3B | 3C | 3D | | | | | 3E | 3F | 38 | 40 | 4F | 54 | 59 | 63 | 68 | | | | |

104 Key U.S. Style Keyboard

| | | | | | | | | | | | | | | | | | | | | |
|----|----|----|----|----|----|----|----|----|----|----|----|----|----|----|----|----|----|----|----|----|
| 6E | 70 | 71 | 72 | 73 | 74 | 75 | 76 | 77 | 78 | 79 | 7A | 7B | 7C | 7D | 7E | • | • | • | | |
| 01 | 02 | 03 | 04 | 05 | 06 | 07 | 08 | 09 | 0A | 0B | 0C | 0D | 0F | 4B | 50 | 55 | 5A | 5F | 64 | 69 |
| 10 | 11 | 12 | 13 | 14 | 15 | 16 | 17 | 18 | 19 | 1A | 1B | 1C | 2B | 4C | 51 | 56 | 5B | 60 | 65 | 6A |
| 1E | 1F | 20 | 21 | 22 | 23 | 24 | 25 | 26 | 27 | 28 | 29 | 1D | | | | 5C | 61 | 66 | | |
| 2C | 2D | 2E | 2F | 30 | 31 | 32 | 33 | 34 | 35 | 36 | 37 | 39 | | 53 | | | 5D | 62 | 67 | 6C |
| 3A | 3B | 3C | 3D | | | | | 3E | 3F | 38 | 40 | 4F | 54 | 59 | 63 | 68 | | | | |

105 Key European Style Keyboard

Calibration Grid

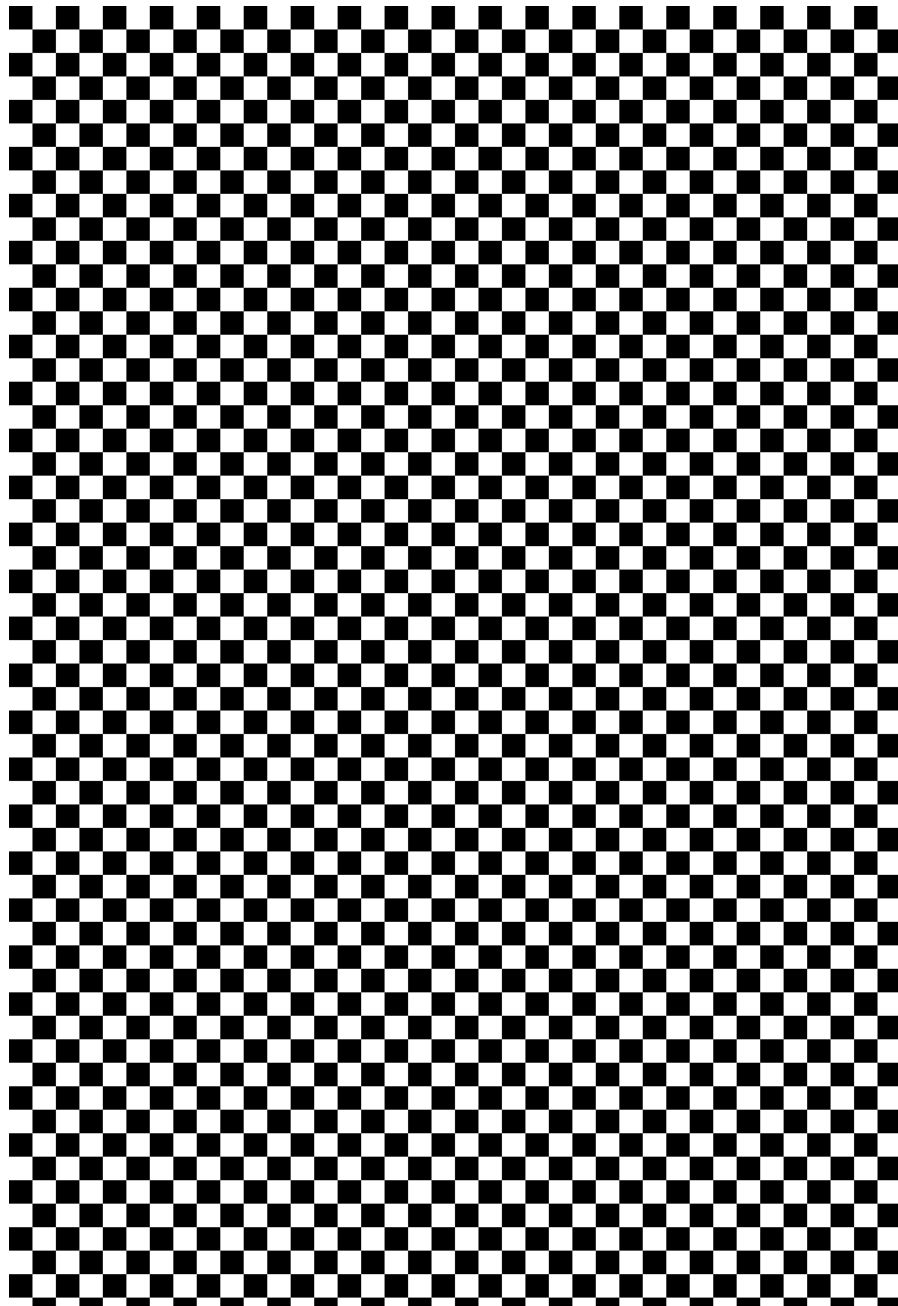

Newland AIDC

 No.1 Rujiang West Rd., Mawei, Fuzhou, Fujian 350015, China

 +86-591-83979500

 info@newlandaidc.com 

www.newlandaidc.com

Asia Pacific

Add: 6 Raffles Quay #14-06 Singapore 048582

Tel: +86 591 83979500

Email: info@newlandaidc.com

Taiwan, China

Add: 7F-6, No. 268, Liancheng Rd.,

Jhonghe Dist. 235, New Taipei City,

Taiwan

Tel: +886 2 7731 5388

Japan

住所: 〒108-0075

東京都港区港南1丁目9-36

アレア品川ビル13階407

電話: +84 03 4405 3222

Korea

Add: Biz. Center Best-one, Jang-eun Medical

Plaza 6F, Bojeong-dong 1261-4, Kihung-gu,

Yongin-City, Kyunggi-do, South Korea

Tel: +82 10 8990 4838

India

Add: Office no. 309-311, 3rd Floor, Tower B,

NOIDA ONE business park B 8, Block B,

Industrial Area, Sector 62, Noida, Uttar

Pradesh 201309

Tel: +91-120-3201449 /50 /51 /52

Indonesia

Add: Eightyeight@kasablanka Tower A 12th

Floor Unit A&H, Jl. Casablanca Raya Kav. 88,

Jakarta Selatan 12870

Tel: +62 21 3950 5400

Vietnam

Tel: +84 969712692

Malaysia

Tel: +60 122042628

Thailand

Tel: +66 971495745

Europe & Middle East & Africa

Add: Rolweg 25, 4104 AV Culemborg, The Netherlands

Tel: +31 (0) 345 87 00 33

Web: www.newland-id.com

Email: sales@newland-id.com

Tech Support: tech-support@newland-id.com

North America

Add: 46559 Fremont Blvd., Fremont, CA 94538, USA

Tel: +1 510 490 3888

Email: info@newlandaidc.com

Latin America

Tel: +1 239 598 0068

Email: info@newlandaidc.com

Chile

Tel: +56 9 9337 3177

Central America & Caribbean

Tel: +52 155 5432 9079

Brazil

Tel: +55 35 9767 6078

Colombia

Tel: +57 319 387 4484

Mexico

Tel: +(001) 323 443-2570

